

DETAIL A
SCALE 2:3

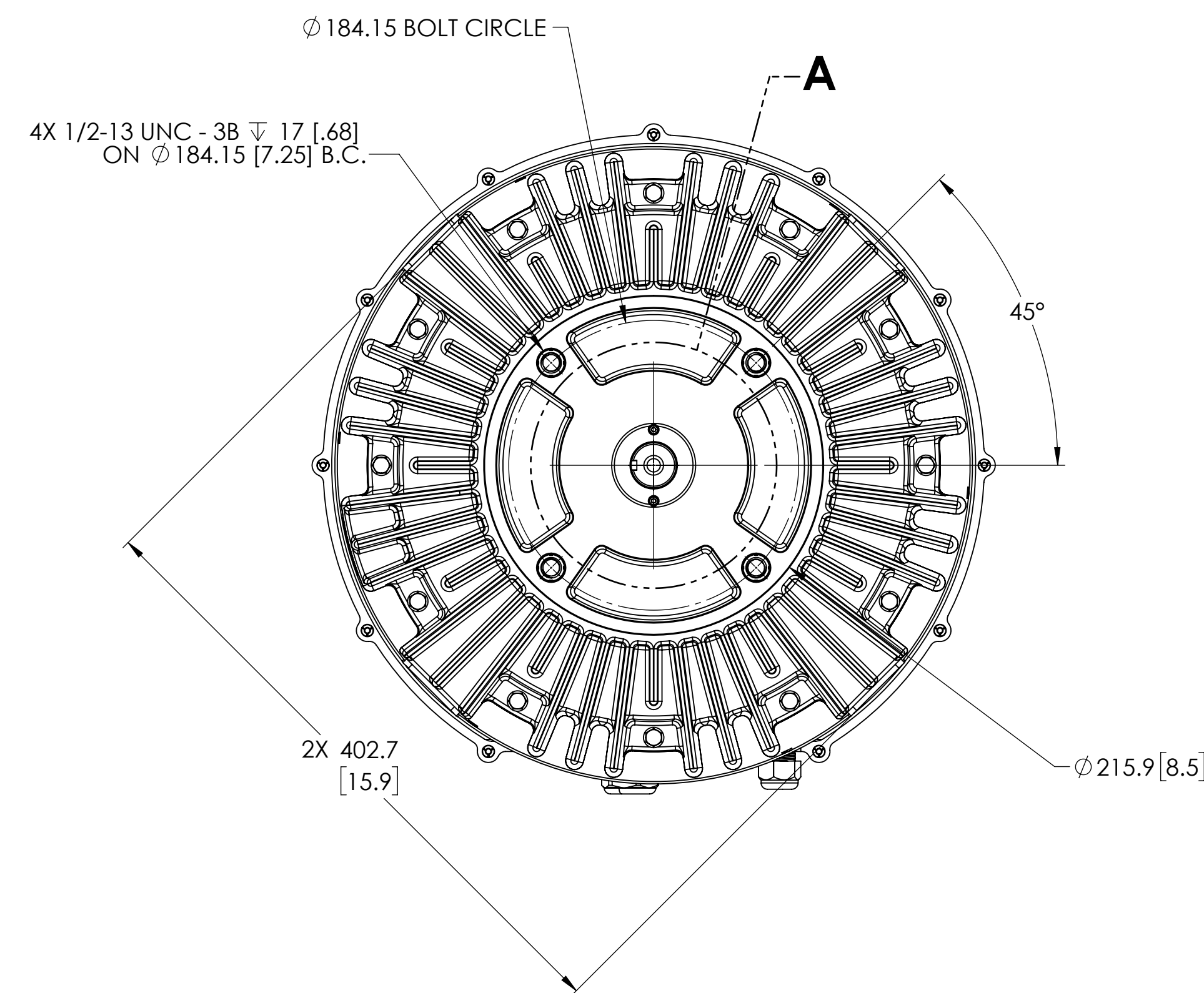
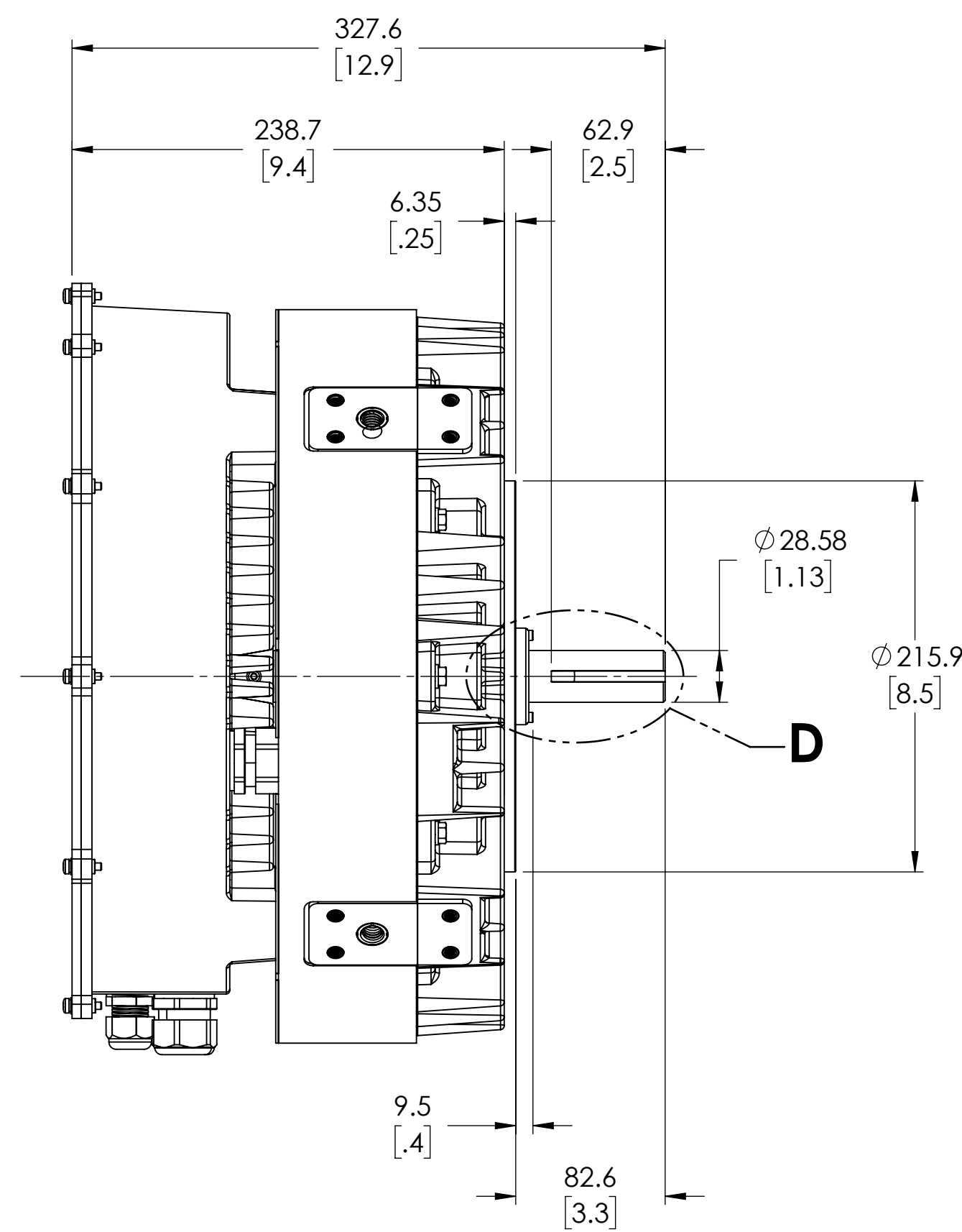
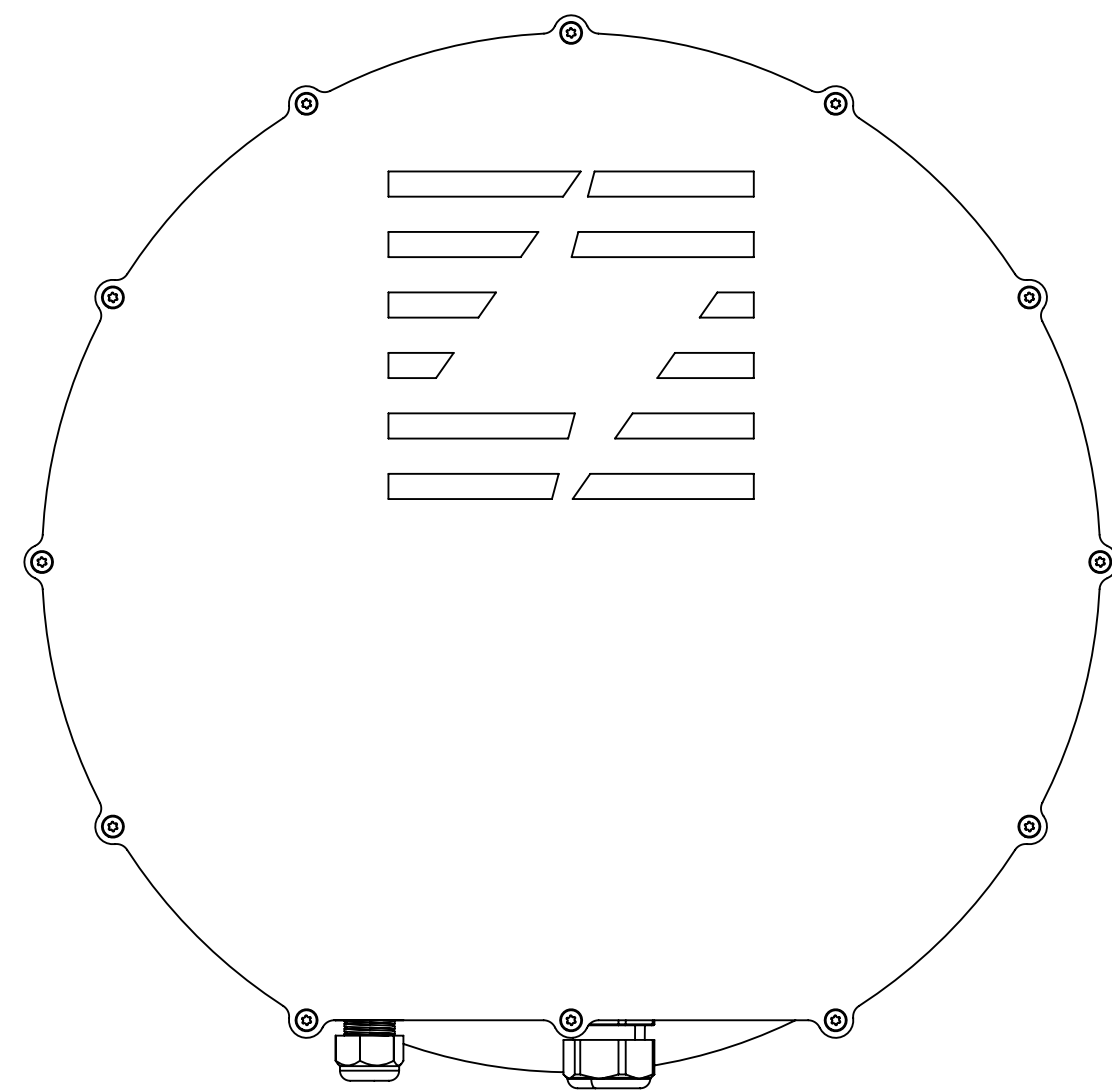
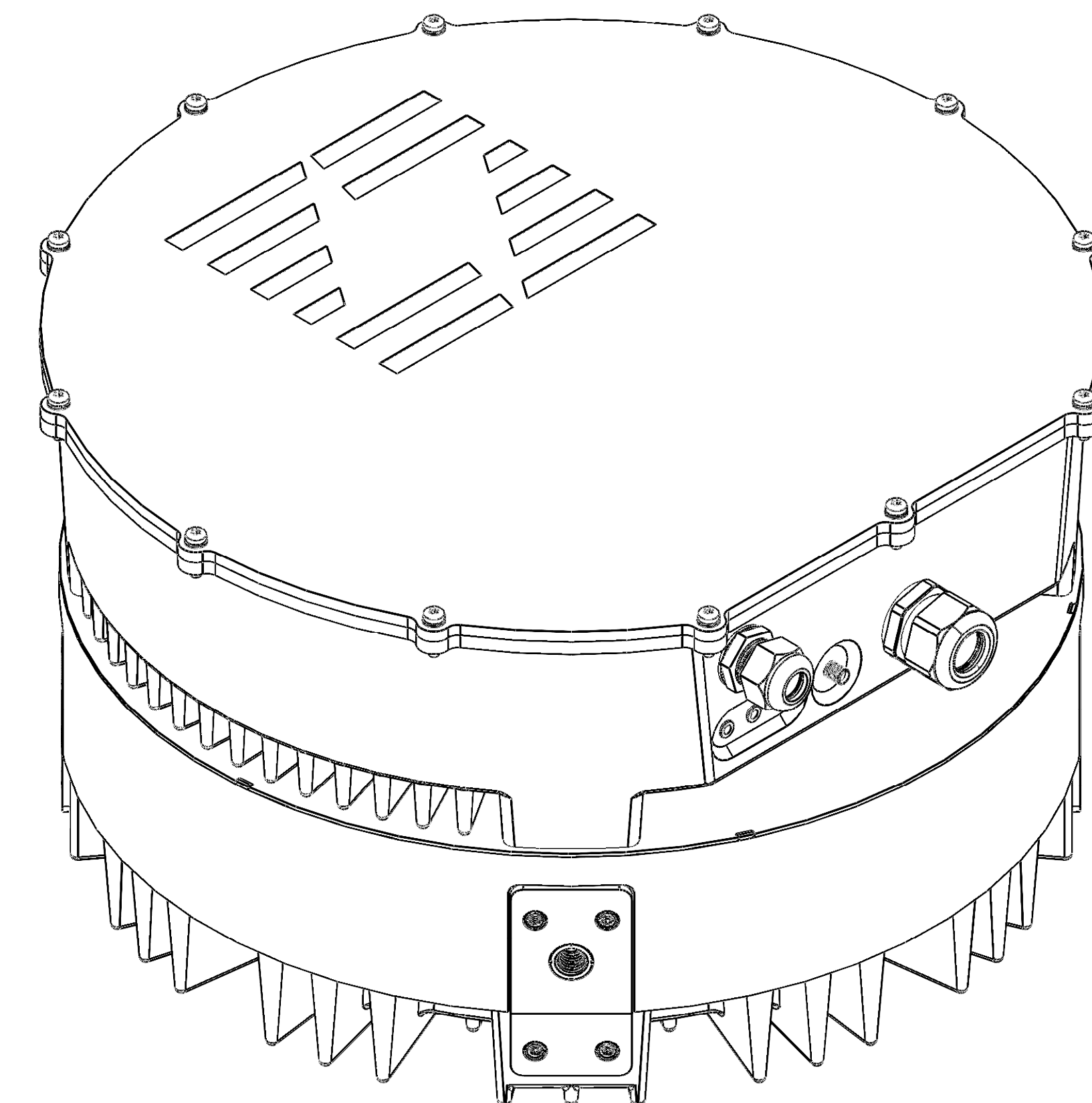

| | | | | | |
|--|--|--|--|---|--|
| UNLESS OTHERWISE SPECIFIED: DIMENSIONS ARE IN MILLIMETERS TOLERANCES: ANGULAR: MACH: ± .5° ONE PLACE DECIMAL: ± 0.3 TWO PLACE DECIMAL: ± 0.15 | | THIRD ANGLE PROJECTION NAME: _____ DATE: _____ DRAWN: REED 04/20/21 CHECKED: REED 4/20/2021 ENG APPR: JMW 09/21/22 | | TITLE: ASSEMBLY, TOP LEVEL, JJ, 7.5-3600, NO ANALOG OUTPUT | |
| MATERIAL: N/A | | FINISH: N/A | | DO NOT SCALE DRAWING | |
| INTERPRET GEOMETRIC TOLERANCING: PER: Y14.5-2009 | | PROPERTY AND CONFIDENTIAL THE INFORMATION CONTAINED IN THIS DRAWING IS THE SOLE PROPERTY OF INFINITUM ELECTRIC. ANY REPRODUCTION IN PART OR AS A WHOLE WITHOUT THE WRITTEN PERMISSION OF INFINITUM ELECTRIC IS PROHIBITED. | | SCALE: 1:3 WEIGHT: 44.84KG SHEET 1 OF 3 | |
| SIZE: _____ | | DWG. NO.: _____ | | REV: _____ | |
| D ASM100098 | | A | | | |