

Datasheet

Aircore EC Frame 15, 5 HP, 1800 RPM



Motor and drive all in one

Integrated variable frequency drive (VFD) facilitates variable speed applications, reducing overall energy usage.

Power more with less

50% lighter, 30% quieter and up to 25% more efficient, averaging \$2,300 in energy savings per motor.*

Powerful intelligence

- State-of-the-art VFD for precise speed control which contributes to energy and audible noise reduction.
- I-con (motor control software) enables users to fine tune operational parameters to their specific applications. Mobile versions available.
- Maximum power density in a 50% smaller and lighter package.

Optimized efficiency

- Meets highest efficiency standards at a wide range of load conditions.
- Increased operational efficiency by eliminating torque ripple, cogging, stator hysteresis and eddy current losses.
- Compact form factor reduces wiring and facilitates direct mounting to fan applications, increasing efficiency by up to 25% compared to a traditional motor.

Sustainable solution

- Our PCB stator uses 66% less copper and is 10x more reliable than traditional iron-core, copper-wound stators.
- Enhanced serviceability due to modular design enables the reuse and extended lifespan of components, keeping them out of the landfill.
- Increased efficiency reduces customer's scope 2 emissions by up to 25%.

Applications



Commercial HVAC



Pumps



Material handling

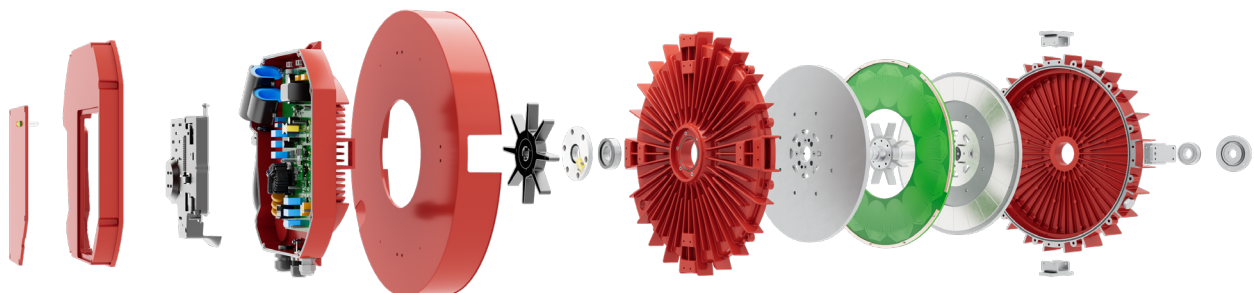

Performance

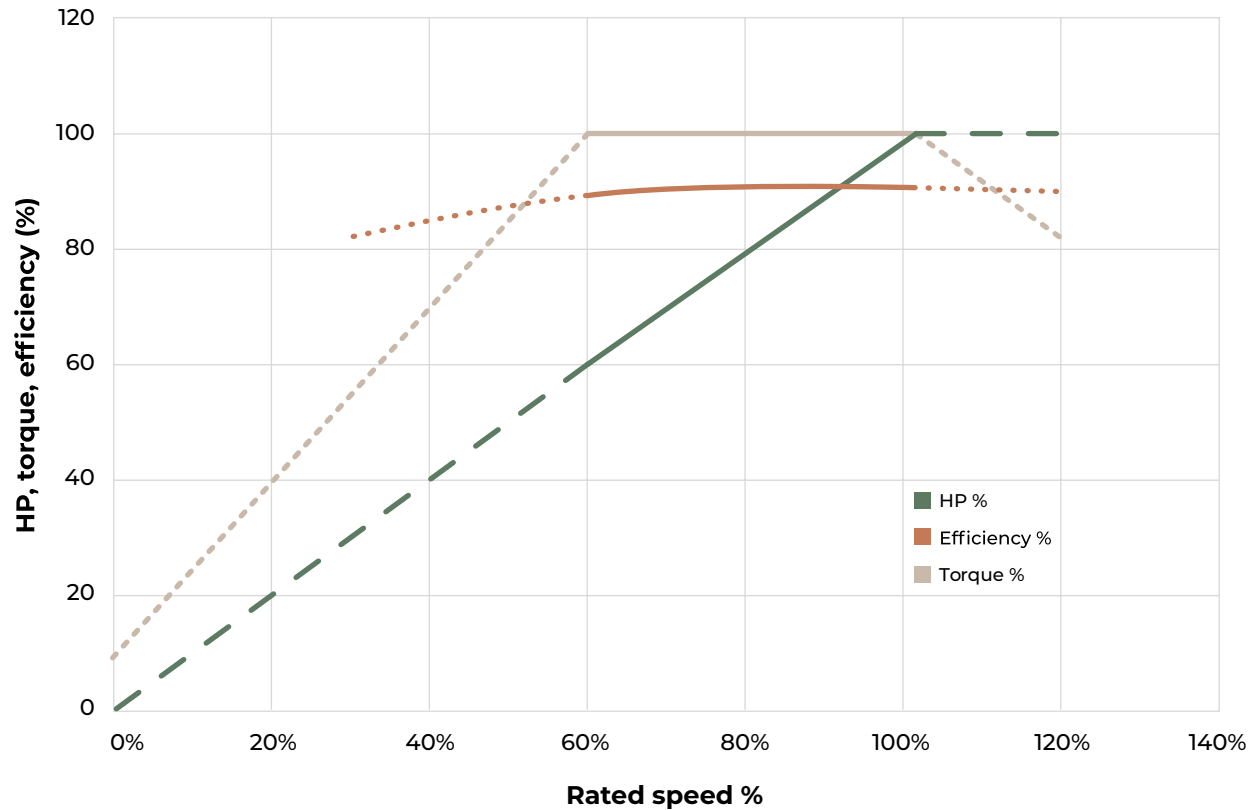

Note: Infinitum does not recommend using the motor below 60% of rated speed at full torque except when coasting or ramping up. It is also essential to restrict power and FLA within the nameplate rating when operating the motor above 100% of its rated speed. To operate the motor outside the recommended operating range, please contact the factory and our Application Engineers will provide a customized solution.

Motor information

Rated power	5 HP, 3.73 kW
Rated torque	14.8 lb-ft, 20 Nm
Rated speed	1800 RPM
Max speed	2200 RPM (see above)
Min speed	540 RPM (see above)
Weight (motor & drive)	85.6lbs, 38.8 kg
Frame diameter	16.4", 41.8 cm
Length (motor & drive)	8.7", 22.2 cm
System efficiency	90.7% (460V), 91.2% (415V)
Duty cycle	Continuous
Variable speed	Yes, integrated VFD
Service factor	1.0
Motor thermal protection	Electronically-protected L
Motor type	TEFC
Enclosure rating	IP54

Electrical

Supply voltage	460 VAC \pm 10%, 415 VAC \pm 10%
Supply phase	3 Phase
Supply voltage frequency	60 Hz \pm 5%
Voltage imbalance	\pm 3% Phase to phase voltage
Short circuit current rating (SCCR)	Input – 5 kA, 500 V maximum
Rated amps	6.0 A (460 VAC), 6.6 A (415 VAC)
Motor insulation class	B
Grounding	Grounded Wye, Delta, HRG

Mechanical

Direction of rotation	CW/CCW
Motor frame material	Aluminum
Rotor inertia	0.49 kg.m ²
Bearing type – DE	Standard: steel, 6206 sealed, permanently lubricated Optional: hybrid ceramic (see catalog number)
Bearing type – NDE	Standard: steel, 6206 sealed, permanently lubricated Optional: hybrid ceramic (see catalog number)
Grease specification	Mobil polyrex EM
Regreasable	No
Grounding brushes	Included – NDE
Shaft design	Keyed
Motor mounting position	Horizontal or vertical
Motor mounting type	C-face (182TC) and body mount

Ambient operating conditions

Condition	Operation	Storage & transportation
Altitude	0 to 3300 ft. (1,000 m) above sea level 9% power derate per 1,000 m up to 4,000 m	NA
Ambient temperature	-13 to 104 °F (-25 to 40 °C) 2% power derate per 1 °C up to 50 °C	-40 to 185 °F (-40 to 85 °C)
Relative humidity	95%, No condensation allowed	95%, No condensation allowed
Contamination levels	No conductive dust allowed	No conductive dust allowed

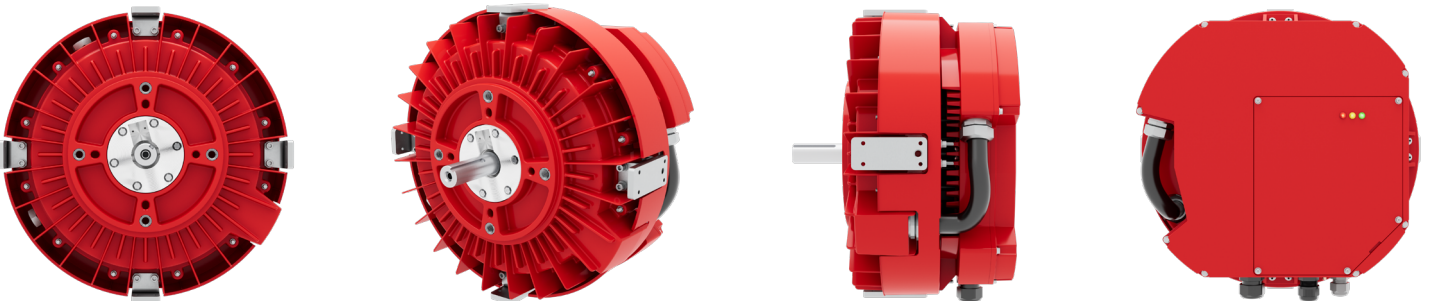

Control connections

Refer to [IOM Manual](#) for more details.

Description	Quantity	Type
Analog input Software selectable for voltage or current input	1	Voltage signal – 0 to 10 VDC, RIN = 20 k Ω Current signal – 4 to 20 mA, RIN = 500 Ω Resolution – 0.1% Accuracy – \pm 5%
Analog output	1	Voltage – 10 VDC with 10 mA maximum for potentiometer
Auxiliary voltage	1	24 VDC \pm 5%, user output, 250 mA maximum
Digital input	4	24 VDC with internal or external supply Input impedance – 1 k Ω
Digital output	2	Open drain output Maximum switching voltage 40 VDC Maximum switching current 350 mA
Relay output	1	Normally open (NO), normally closed (NC) contact arrangements Maximum switching voltage of 125 VAC / 30 VDC Maximum switching current of: NO – 10 A (VAC) / 5 A (VDC) NC – 3 A (VAC) / 3 A (VDC)
EIA-485 Interface for Modbus RTU	1	Shielded twisted pair cable with impedance of 120 Ω Half duplex Modbus RTU communication protocol
Modbus TCP	1	Ethernet for I-con

Certifications

Regulatory	
UL 1004-7	Standard for electronically protected motors
UL 1004-1	Rotating electrical machines – general requirements
CSA C22.2 No.77	Motors with inherent overheating protection
UL 61800-5-1	Standard for adjustable speed electrical power drive systems, Part 5-1: safety requirements & electrical, thermal & energy

Mounting & dimensions mm [inches]

Below are the measurements needed for installation tasks.

- There are four mounting pad locations.
- Each pad is spaced 90° apart, containing 4 mounting holes and one lifting eye hole.
- The DE face of the mounting block has threaded holes for four bolts (1/2"-13).
- All bolt holes should be used for secure mounting of the motor to equipment.

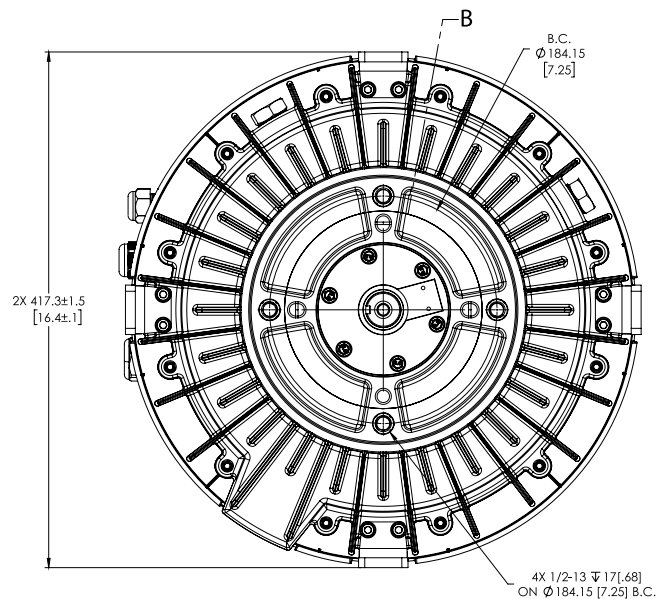
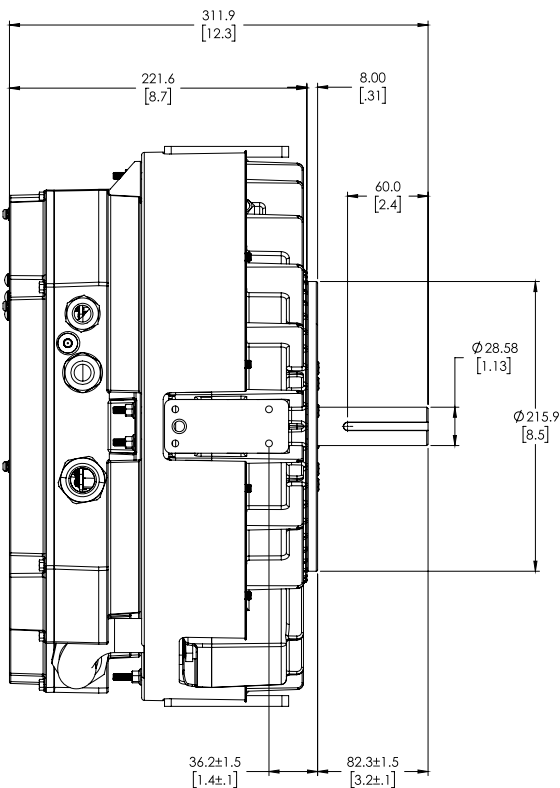
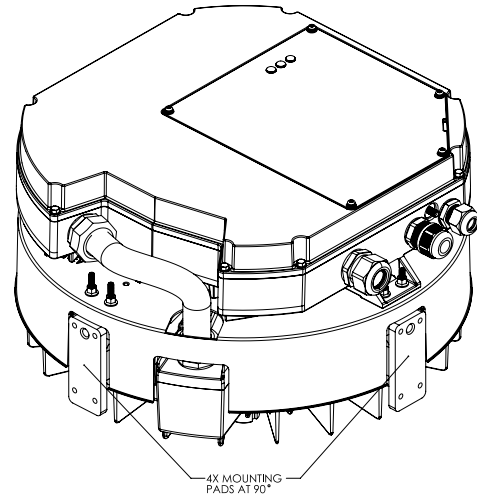
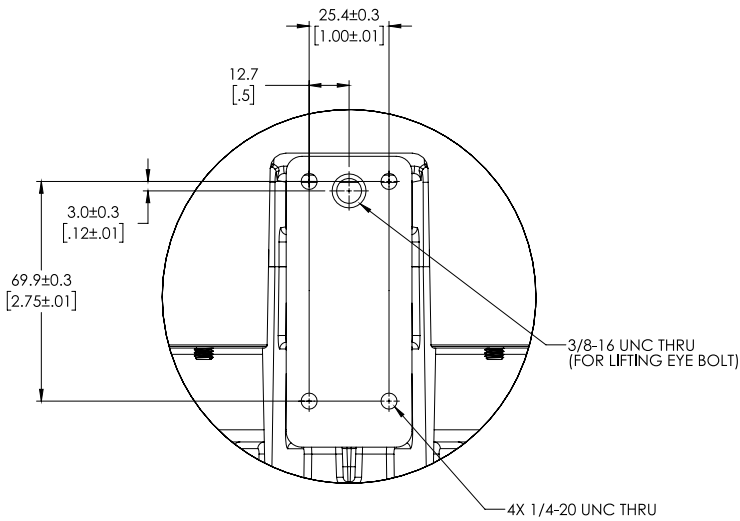

Catalog number decoder

Family	Frame	Rated power	Rated speed	Volts	VFD & I/O	Reserved	Bearings	Shaft Length	Wireless Support	IP rating	Grounding
XX	XX	XXXX	XXXX	X	X	X	X	X	X	X	X
AE	15	0500	1800	A: 460 V / 60 Hz B: 415 V / 60 Hz	A: Modbus RTU B: BACnet MS/TP	A: none	S: steel H: hybrid	A: 3.25"	A: none	4: IP54	0: Grounded Wye 3: Delta, HRG

Ordering information

Catalog number	Modbus RTU	BACnet MS/TP	Steel bearings	Hybrid bearings	Grounded Wye	Delta, HRG
460V						
AE15-0500-1800-AAAS-AA40	X		X		X	
AE15-0500-1800-AAAH-AA40	X			X	X	
AE15-0500-1800-ABAH-AA40		X		X	X	
AE15-0500-1800-ABAS-AA40		X	X		X	
415V						
AE15-0500-1800-BAAS-AA40	X		X		X	
AE15-0500-1800-BAAH-AA40	X			X	X	
AE15-0500-1800-BBAS-AA40		X	X		X	
AE15-0500-1800-BBAH-AA40		X		X	X	
AE15-0500-1800-BAAS-AA43	X		X			X
AE15-0500-1800-BAAH-AA43	X			X		X
AE15-0500-1800-BBAS-AA43		X	X			X
AE15-0500-1800-BBAH-AA43		X		X		X



We reserve the right to make technical changes or modify the contents of this document without prior notice. Copyright© 2024 Infinitum Electric, Inc. All rights reserved.

Office

106 Old Settlers Blvd
Suite D106
Round Rock, TX 78664

Contact

info@goinfinitum.com
goinfinitum.com
support@goinfinitum.com

* Infinitum motor system compared to IE4/ NEMA Super Premium AC Induction motor + VFD over a 10-year lifetime. Efficiencies are dependent on specific motor and application.