



Aircore EC

I-con Software manual

Version 2.99

Date: April 27, 2026

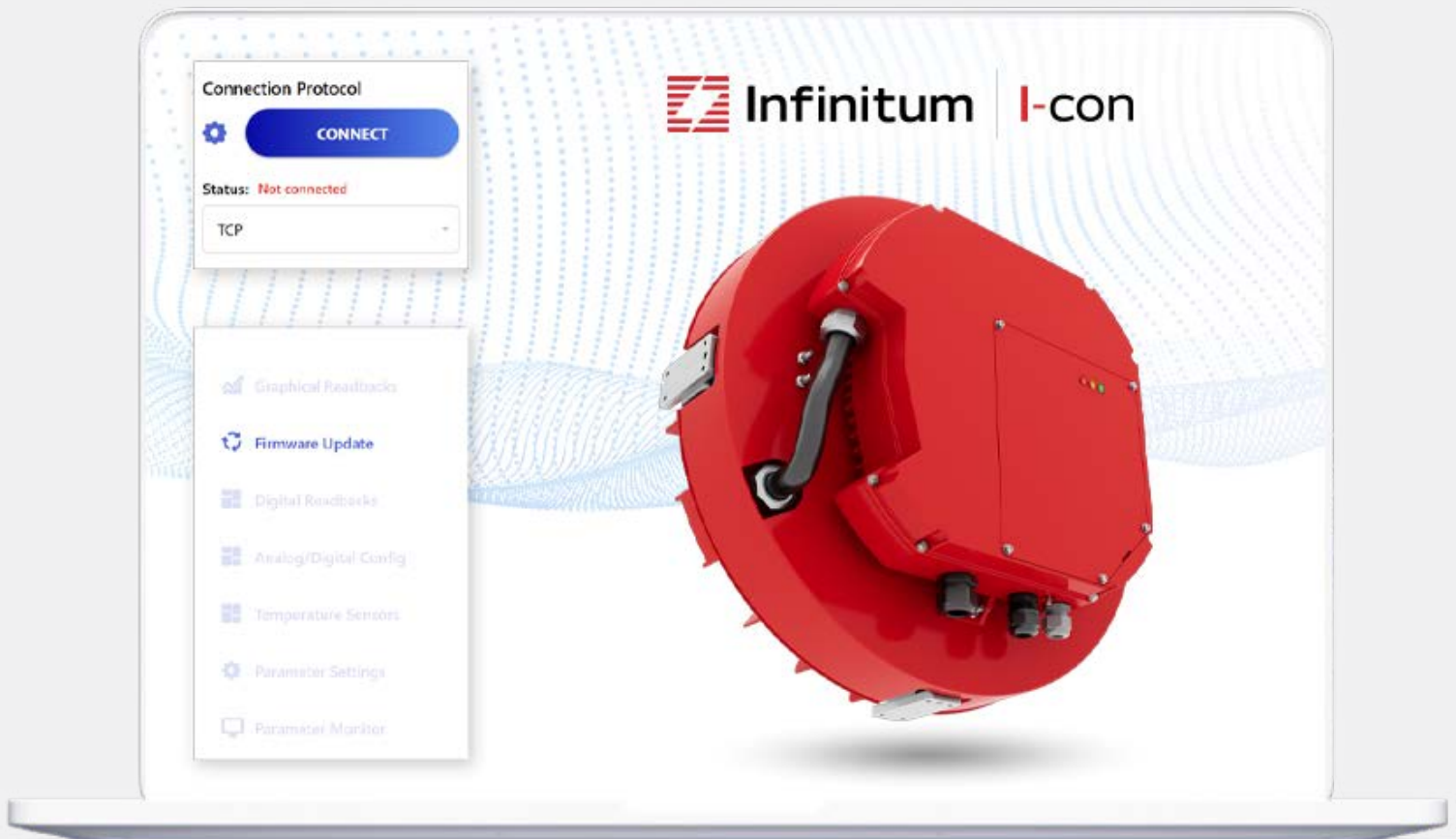
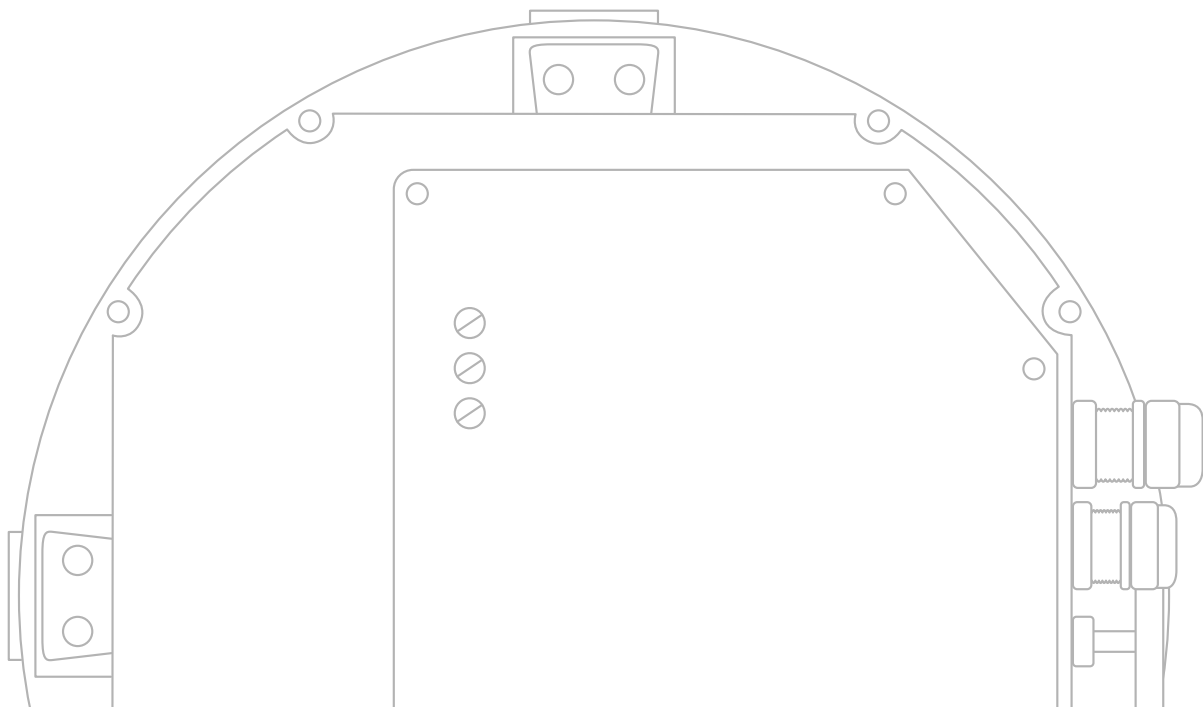

Table of Contents

1. Overview	3	4. New Features	8
2. Computer setup	3	Override	8
Setting static IP address (Windows 10 Professional)	3	Analog Level Control	8
Windows x86.NET Core	3	Analog Fail Over	8
I-con Software	3	5. Parameter Settings	9
3. I-con Operations	4		
Configure motor for AC input	4		
Ethernet connection to motor	4		
Serial connection to motor	4		
Connecting I-con to the motor	4		
Motor Configuration	5		
Graphical Readbacks	5		
Analog/Digital Config.	5		
Temperature Sensors	6		
Parameter Settings	6		
Parameter Monitor	6		
Motor Information	6		
Support	7		
Firmware update	7		
Firmware update instructions	7		
Motor Operation	7		



Overview

I-con software allows the user to utilize the advanced functions of the Infitum Aircore EC motor family. I-con requires Windows based computers. Windows based computers.

Refer to Product Notice PN:25-04 for additional information.

Control connections

Remove the VFD cover for access to Analog/Digital, Modbus and (optional) BACnet connections.

1. Relay (1) – NO / NC (COM must be used)
 - Max voltage: 125 VAC / 30 VDC
 - Max current: NO-10A VAC, 5 A
 - VDC: NC – 3A VAC or VDC
2. Digital input (4) – DIN1, DIN2, DIN3, DIN4
3. Digital output (2) – DO1 & DO2
 - Open drain output
 - Max switching voltage: 40 VDC
 - Max switching current: 350 mA
4. Auxiliary voltage (1) – +24V (GND must be used), 250 mA max
5. Analog output (1) – A_OUT (GND must be used) 10 V, 10 mA max
6. Analog input (1) – A_IN (GND must be used)
7. EIA-485 interface (1) – 485_P & 495_N (Modbus RTU or BACnet MS/TP)

Note: Use wirenut to connect shield wires. Do not tie to GND.

8. EIA-485 termination switch. (Default is Off)
9. RJ45 (ethernet) for I-con (motor control software) connection
10. Optional BACnet module
11. USB

Computer setup

All computers that communicate with an Infitum Aircore EC Motor must use a static IP Address. If the correct static IP address is not configured, the computer will not communicate with the motor. See Figure 1.

Setting static IP address (Windows 10 Professional)

1. Click **Start Menu > Control Panel > Network and Sharing Center or Network and Internet > Network and Sharing Center.**
2. Click **Change adapter settings.**
3. Right-click on **Wi-Fi or Local Area Connection.**
4. Click **Properties.**
5. Select **Internet Protocol Version 4 (TCP/IPv4).**
6. Click **Properties.**
7. Select **Use the following IP address.**

8. Enter the **IP address: 172.17.20.153 Subnet mask, Default gateway, and DNS server: 255.255.0.0**
9. Click **OK.**

Note: When motor operation is completed, the default selection of “Obtain an IP address automatically” must be reestablished if computer connectivity via Ethernet is desired.

Figure 1 Static IP

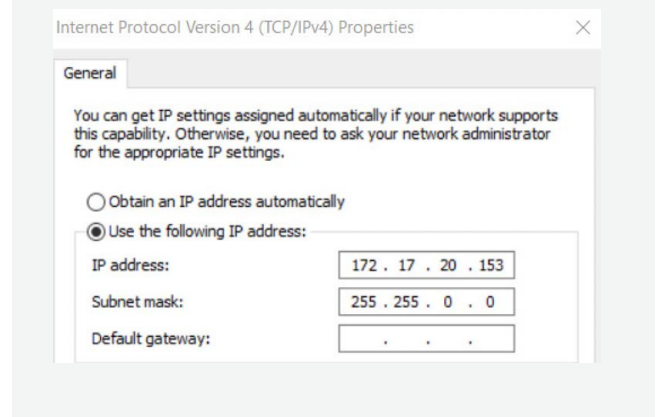
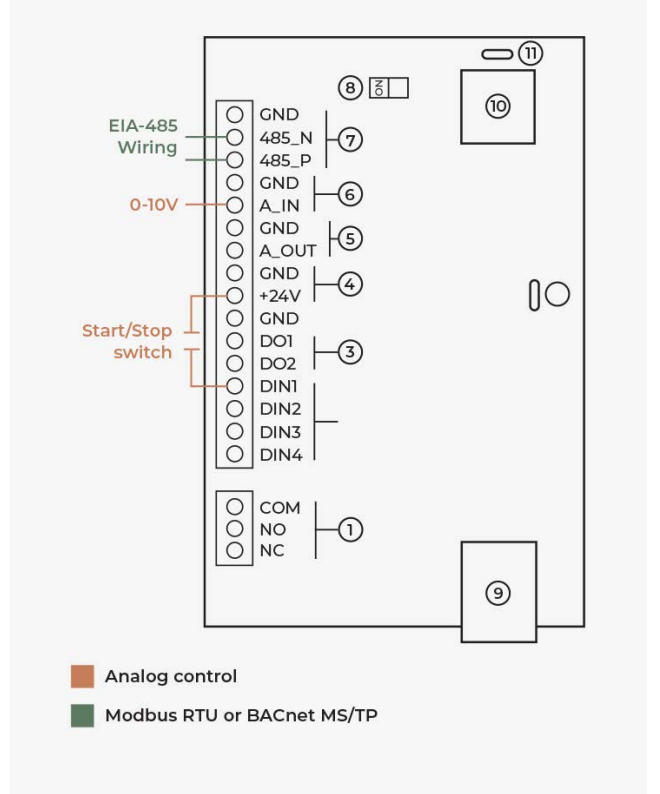

Figure 2: CIM board



Windows x86.NET Core

This computer also needs to have Windows x86 .NET Core installed. The SDK for this installation is [here](#).

After installing the SDK, restart your computer for the installation changes to take effect.

I-con Software

I-con should now be downloaded to this computer. The installation package is found on the Infinitum support page [here](#). Release notes are included in the download package. I-con is installed on the laptop or computer: C:\Program Files (x86)\Infinitum-Icon\MotorControl.Engineer. The installer also creates a shortcut to the software on the desktop of the computer.

I-con Operations

The CIM board in Infinitum motors provides the control wiring connections. (Figure 2) I-con can communicate with Infinitum motors using TCP (Ethernet) or Serial. TCP utilizes a RJ45 connector. Serial connections are completed at the EIA485 connections.

Configure motor for AC input

Warning: Always Tagout and Lockout the electrical motor circuit and practice all company safety procedures when installing, troubleshooting, or repairing a motor. Always verify power is secured with a multimeter prior to work. Failure to adhere to Tagout/Lock and industry standard practices can result in serious personal injury or death and equipment damage.

The motor must be installed onto an approved test bench or installed into the equipment it serves. AC wiring connections are identified in Figure 3.

Ethernet connection to motor

Connect a standard ethernet cable from the laptop/PC to the motor. RJ45 female connector is connected to CAT 5, CAT 5e, CAT 6, CAT 6A or CAT 7 cable. Use connector (9) on the communication card. This computer requires the static IP address mentioned above.

Serial connection to motor

If a serial connection to the motor is preferred, connect a serial cable from the laptop/PC to the motor. The serial connection on the Infinitum motor is on the CIM card, accessible when the VFD access port or VFD cover is removed (depends on version of the VFD). The Serial connections are identified as 485_P, 485_N, (7) on the CIM silkscreen. Polarity must be maintained from the VFD access port to the computer. The motor also supports a Micro USB connection.

Connecting I-con to the motor

I-con software needs to “CONNECT” to the motor for control. This connection is a two-way handshake between the application running on the computer and the firmware running in the motor VFD. The Connection Protocol is a pull-down option in the upper left of the I-con home page. For an ethernet connection (default) the protocol should be TCP. This connection can be changed to “Serial” if a serial connection is desired. See Figure 4.

Figure 3: AC connections



Power on the motor. If I-con software is running on the computer, a connection with the motor will be established when the motor is powered on. The “Status” will go from “Not Connected” to “Connected” once this connection is established.

If the motor is powered on after I-con software is started, the connection must be established manually. To establish this connection, use the blue “CONNECT” button in the upper left of the window as shown in Figure 4.

Figure 4: GUI

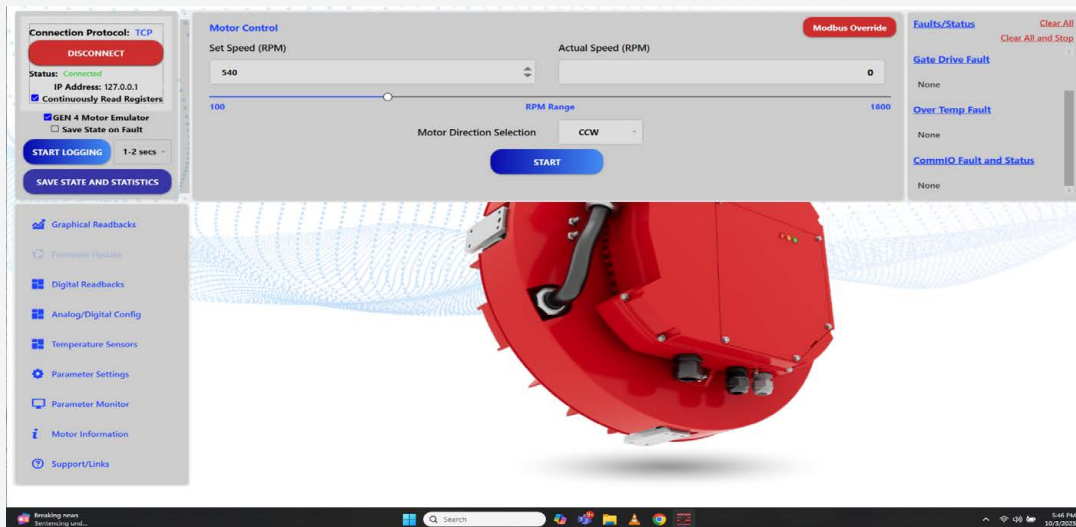

Once the motor is connected to the computer, the “Status” in the upper left box should indicate “Connected” in green text and the connect button changes to a red “DISCONNECT” button as indicated in Figure 5. This button is used to break the connection between I-con and the motor.

Motor Configuration

While connected, the following data can be set or read by I-con for parameters of the motor.

The upper portion of the I-con window is for real-time motor information and control. The lower portion is to configure motor operational parameters.

Real-time motor information: Upper portion of window

- Connection Protocol: TCP or Serial
- Connect or Disconnect: Button to establish or break the communication link with the motor
- Status: Connected or Not Connected (Connection status to motor)
- IP Address: Address used for ethernet connection
- Continuously Read Registers- Check box for continuous data updates. Uncheck to validate Fail Over features
- Gen 4 Motor Emulator- Check box to enable motor emulation. If checked user can connect to motor and perform any operation except firmware updates on a “virtual motor”.
- Save State on Fault- Logs faults to a user selectable file
- Start Logging: Real-time data logging. If logging is selected, I-con will prompt a directory to record the log file. The default is the Windows Documents directory. The log file is a standard Windows Excel file. The frequency of the logging is user selectable via the pull-down choices

- SAVE STATE: Saves values of all software parameters in a JSON file
- Motor Control: Allows Speed and Direction control: Set Speed, Actual Speed, RPM range, Motor Direction, Start/Stop indicator
- Modbus Override: Restores Modbus communication to motor
- Faults/Status: Operational Fault and Status indications. “Clear All” removes all fault indications. “Clear All and Stop” removes fault indications and stops motor.

User Information: Lower section of window

Some information below may look slightly different due to different versions of the Communications Interface Module (CIM) and Inverter board firmware.

Graphical Readbacks

Displays operational parameters in graphical format. X and Y axis values are user settable. Options include Stator Temperature and Speed. The graph Period is selectable (30 sec – 1 hr. in 15 min increments)

Analog/Digital Config.

Displays values for motor functions including Analog In 1 Function, Analog In 1 Minimum Setting, Analog In 1 Maximum Setting, Analog In 1 Type, Analog Out 1 Function, Analog Out 1 Type, Digital In 1 Function, Digital In 2 Function, Digital In 3 Function, Digital In 4 Function, Digital Out 1 Function, Digital Out 2 Function

Temperature Sensors

Realtime information on Stator Temp Average (°C), Heat Sink (Internal Case) Temp (°C), Stator Thermistor 1 Temp (°C), Inverter Board Temp (°C), Stator Thermistor 2 Temp CIM Temp (°C), CIM Board Temp (°C)

Parameter Settings

Users can change many key operational parameters.

These include:

- › Operating Limits
- › Operation Type
- › Communication Settings
- › Analog Fail Over Settings
- › Fault Reset
- › Terminal Settings
- › Modbus Fail Over Settings.
- › [Parameter settings](#)

Use the “APPLY” button to save this information in the motor if you change any values. “RESTORE” returns the configurable settings to the factory default.

All information and setting options are available via pull-down settings or direct numerical input into the software. For more information, see the [Aircore EC Motor Drive Control Software Overview Video](#) on the [Infinitum support site](#). It is in the “Videos” section. We recommend viewing the I-con video before starting your motor.

Parameter Monitor

Parameter Monitor displays live information on the settings established by the Parameter Settings function. These include Parameter Monitor.

Monitor Operating

- › Run/Stop Actual
- › Direction Actual
- › Speed Actual

Monitor Performance

- › Consumed Power (MWh)
- › Drive Run Time (hr)
- › Motor Run Time (hr)
- › Output Torque (Nm)
- › Output Power (W)

Monitor- DI/DO

- › DI1 Value
- › DI2 Value
- › DI3 Value
- › DI4 Value
- › DO1 Value
- › DO2 Value

Operating Limits

- › Motor Max Current (A)
- › Speed Motor Type Min
- › Speed Motor Type Max
- › Max Acceleration (RPM/s)
- › Max Deceleration (RPM/s)
- › System Input Current (A)

Monitor - AI/AO

- › AI1 Value (%)
- › AO1 Value (%)

Digital Readbacks

- › Calculated Input RMS Voltage (V)
- › Calculated Input RMS Voltage (V)
- › Output Power (W)
- › Output Torque (Nm)
- › DC Bus Voltage (V)
- › Stator RMS Current (A)

Motor Information

Displays motor operational information.

- › Motor Serial Number
- › Motor Voltage (V Rated Speed (RPM)
- › CIM (Communication Interface Module) Firmware version
- › Inverter (firmware) version
- › Catalog (Orderable) Number

Support

Link to Infinitum support site [Infinitum support site](#).

Firmware update

Firmware for the CIM and Inverter boards in the motor can be updated via I-con. Updating the firmware can add extra capabilities and/or fix bugs that occur during operation in the field and testing. The firmware files can be downloaded from the Infinitum support site

The firmware update connection from a laptop can be made via TCP (ethernet) or Serial. In the serial mode it is possible to update multiple motors sequentially on the serial bus. The motors will be identified by their slave address in the update process. .

The firmware update process provides completion information via the Status box.

The motor cannot be "Connected" during a firmware update. Make sure the blue Connect button (1) is visible in the upper left hand corner of the I-con window. The motor should be powered on. If red Disconnect button is visible, click it to disconnect motor.

The "Firmware Update" button should now be visible.

The following updates can be made:

- Inverter Binary - Inverter software
- CIM Binary- CIM software

Firmware update instructions

1. Download the file(s) you wish to update from the Infinitum support website to your PC or laptop
2. The connection from I-con to the motor can be established using Ethernet (TCP) or Serial. Use the pull-down tab beside the "gear" symbol to choose your desired connection method
3. Use the "Select Files to Upload" feature to upload the specific files you wish to change into the Motor Drive Control Software. You can do the CIM and/or Inverter files.
4. Once all desired files are uploaded, hit the "CONNECT" button (beside the blue Upload button). There should be green text displaying "Connected."
5. Click the UPLOAD button to move the selected files from the PC/Laptop to the motor.
6. The Status window should start updating to show upload progress.
7. Once the update is complete, the Firmware Update window closes.
8. The motor can be connected to the Motor Drive Control Software after update is complete using the "CONNECT" button in the top Connection Protocol box.

Motor Operation

After setting the correct parameter settings, you can "START" your motor, using the blue START button in the upper window of I-con. After starting, the motor runtime information will be displayed including the "Actual Speed". The speed can be controlled via the "slider", the up/down arrows on the Set Speed, or by writing the desired speed into the Set Speed location. Realtime motor information is available in the Parameter Monitor window.

IMPORTANT

ALWAYS USE ICON v2.99 TO UPDATE CIM AND INV FIRMWARE TO THE GEN4.2 PACKAGE. USING AN INCOMPATIBLE ICON VERSION COULD CAUSE ERASURE OF NON-VOLATILE MEMORY RESULTING IN INCORRECT MOTOR OPERATION. CONTACT INFINITUM SUPPORT FOR MORE QUESTIONS.

New Features

Override

Override is a feature that sets the motor to a preset constant speed. Override can be initiated by writing to a Modbus parameter register (1210) or by using one of the four programmable Digital Inputs or by providing a voltage on Analog In within the range established via the All Override Min and Max settings. If a Digital Input is used, a high value on that Digital Input bit will trigger Override. The motor Override speed is programmed via the Override Speed (RPM) found in the I-con Terminal Settings or by setting the Override Speed parameter register (2205). Note: To use the voltage range (analog) version of Override, the Speed Input Source and Start/Stop Input Source must both be in Modbus mode. Gen4.2 supports 'DI1 and Start' option for Override. This option starts a motor currently in a stop condition, upon DI1 activation.

Analog Level Control

Legacy Infinitem analog motor control requires a Digital Start/ Stop input as well as an Analog Input using a 0-10V input source. This requires a 4-wire connection to a motor. Gen4.1 now features an "analog level control" feature that provides Start/Stop capability as well variable analog speed control, requiring only two wires. This analog control is enabled by establishing "Stop Range" and a "Run Range" in the Analog Input settings. The "Stop Range" is defined to establish a voltage range that stops the motor with an analog signal in that range. The motor will start once the input voltage is greater than the Analog In Minimum setting (i.e. the Run Range). As the voltage increases above the Analog In Minimum, the speed will increase until it reaches the User Maximum speed at the Analog In Max value.

Deadband zones are voltage ranges where no actions are initiated in the motor. These ranges are optional but useful if the input voltage has variability. Deadbands help establish boundaries between the various ranges. Analog Level Control Input Ranges (specific voltage values are just suggestions for clarity).

Analog Fail Over

I-con 2.96 adds an additional feature that leverages the Analog Level Control feature mentioned previously. Analog Fail Over is a condition where the motor speed control can be preset if the Analog control signal is lost. Like Analog Level Control, Analog Fail Over uses Analog In voltage ranges to establish regions where different functions are performed depending on the input voltage levels. A Stop Range is established as above utilizing the Analog Stop Minimum and Analog Stop Maximum values. A Failover Range is established below the Stop Range to establish voltage minimums and maximums for fail over operation.

The Fail Over Speed value is set using the Analog Input Open Speed parameter (2011). This speed should be in RPM. See the ranges below. The specific values are just suggestions. Analog In Open Max must be non-zero. The voltage values are just suggestions.

Analog Fail Over operates like Analog Level Control with the motor responding to the varying voltages on Analog In. If the input voltage on Analog In is between 0V and Analog In Open Max the motor will start and run at the Fail Over Speed set in the Analog Input Open Speed parameter. This speed could be zero for the motor to stop in analog Fail Over mode. Increasing the input voltage into the Stop Range, between Analog In Stop Min and Analog In Stop Max, the motor will Stop. If the input voltage is greater than Analog In Min the motor will start running, with the speed determined by the value of the voltage. As the voltage increases the motor operational speed will increase. The User Maximum Speed aligns with the maximum voltage, Analog In Max.

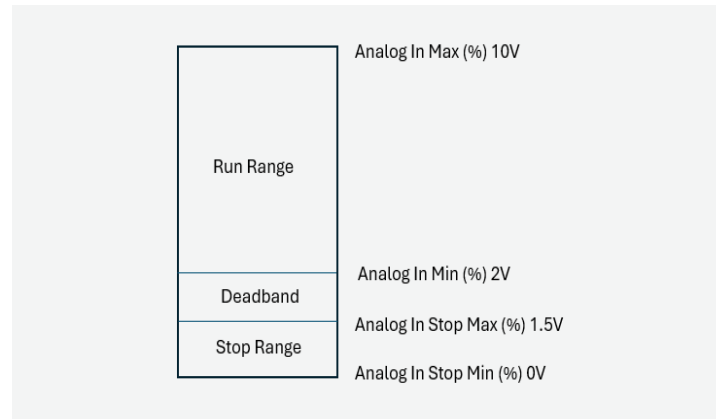

If there is a loss of voltage on Analog In, the motor will be in the Fail Over operation mode and will operate at the speed established by the value in the Analog Input Open Speed register. The Fail Over speed could be zero or the failover max percentage, so in this case, the motor will stop in Analog Fail Over mode. Gen4.2 supports a stop option as well as a Fail Over Speed' Gen4.2 supports a All Timeout function, during which an All Open condition is ignored.

Note: if Analog Fail Over values are established, the motor will start and operate at the value established in the Analog Input Open Speed register as soon as power is applied and the Analog In voltage is zero or in the Fail Over Range (zero to Analog In open max). To stop the motor in this state, the Analog In voltage must be in the stop range.

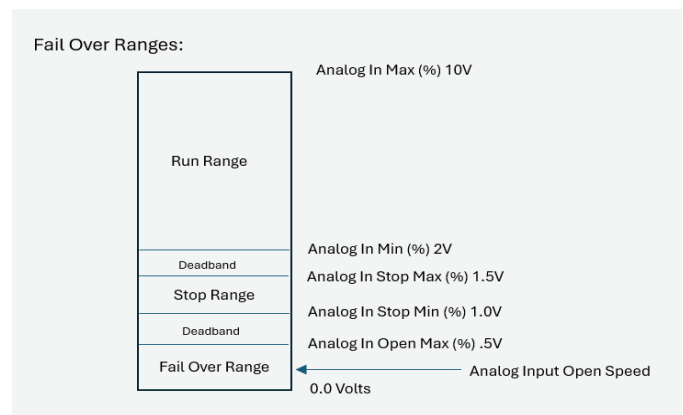

Parameter Settings

This section describes motor drive settings that can be updated using I-con.

Refer to the latest [Parameter Settings](#) available.



We reserve the right to make technical changes or modify the contents of this document without prior notice. Copyright© 2026 Infinitum Electric, Inc. All rights reserved.

Office
12234 N IH 35 SB
Building B
Austin, TX 78753

Contact
info@goinfinitum.com
goinfinitum.com
support.goinfinitum.com