

# Aircore EC+ BACnet User Manual

BACnet Version 1.4  
Release: Gen4  
Date: October, 2025

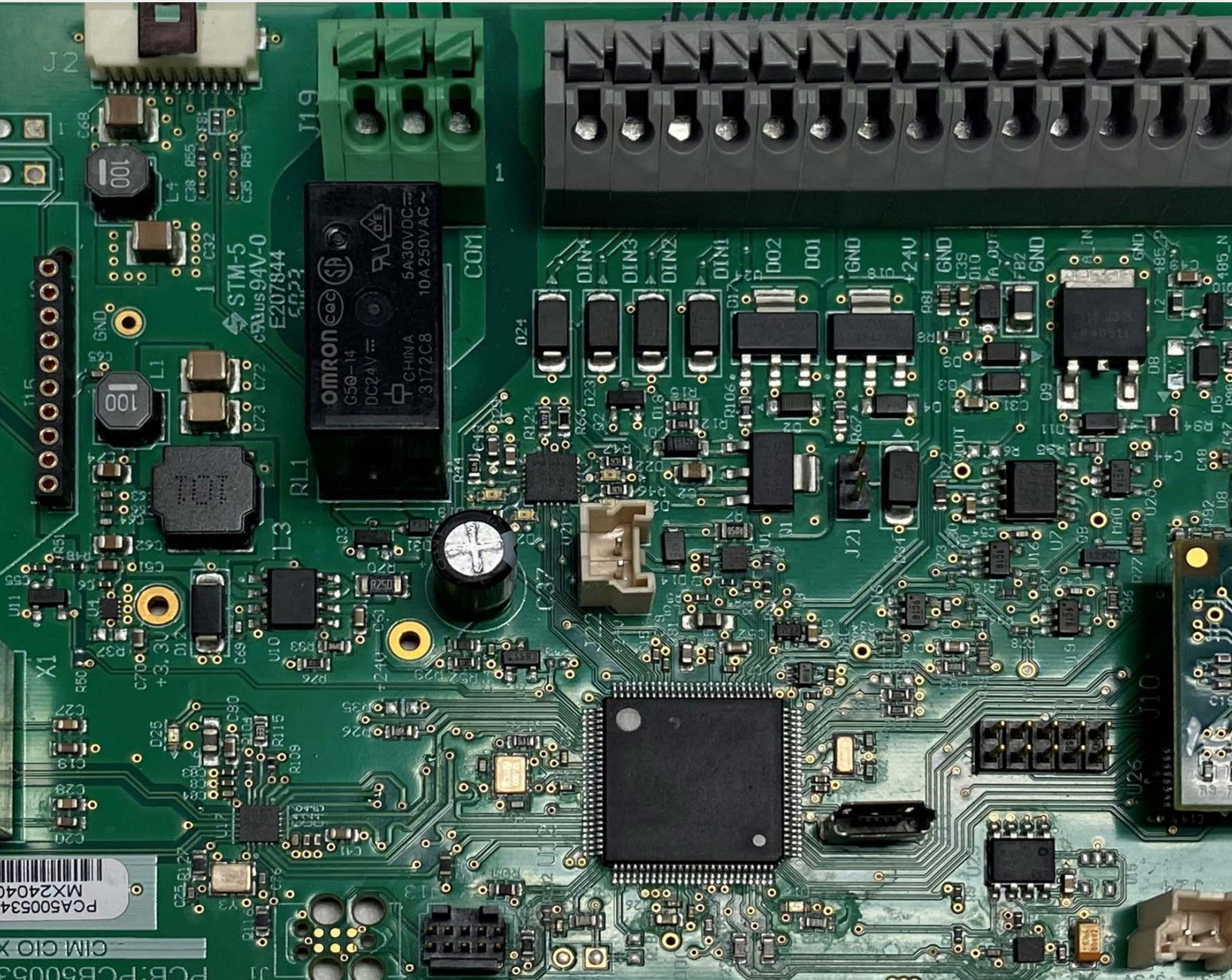

# Table of Contents

<b>1. About the Manual</b>	<b>3</b>
<b>2. Introduction to BACnet Communication</b>	<b>3</b>
<b>3. BACnet: Installation and Field Wiring Hardware</b>	<b>4</b>
<b>4. BACnet Module: Installation</b>	<b>4</b>
<b>5. BACnet Module, Field Wiring</b>	<b>5</b>
<b>6. Terminating Resistor</b>	<b>6</b>
<b>7. BACnet Module, Programming</b>	<b>6</b>
<b>8. NPU Tool</b>	<b>6</b>
<b>9. BACnet Baud Rate and Address</b>	<b>7</b>
<b>10. Appendix &amp; Troubleshooting</b>	<b>10</b>

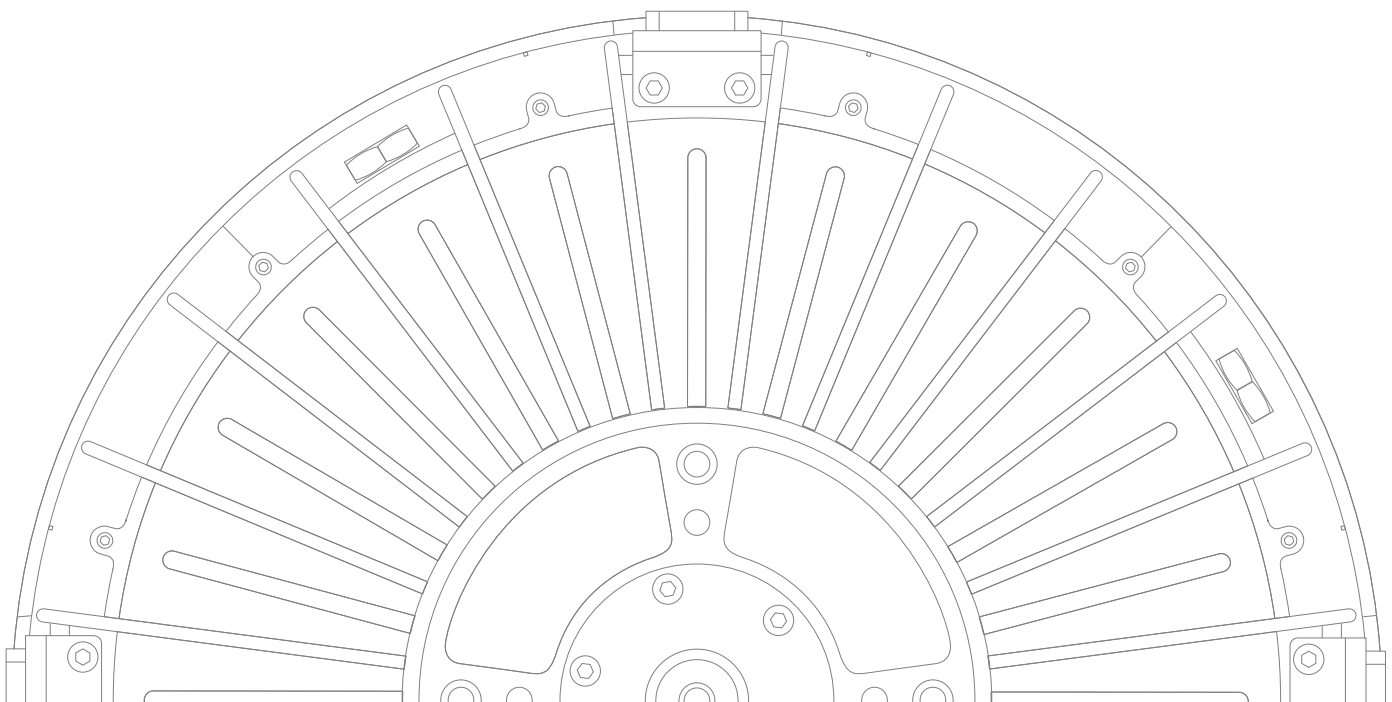

# 1. About the Manual

This manual describes the information needed to operate Infitimum Aircore EC+ motors using the BACnet protocol. This manual should be used in conjunction with the [Aircore EC+ Installation Operation and Maintenance \(IOM\) Manual](#).

## Abbreviations

BACnet	Building Automation Control Network
BACnet MS/TP	BACnet Master-Slave Token Passing

# 2. Introduction to BACnet Communication

BACnet is a common motor control protocol used in HVAC applications. This protocols is defined by ANSI/ASHRAE/ISO Standard 135-2004. The protocol is used for building automation and control describing the interaction between devices and systems. The protocol uses an object-oriented model for data and commands. BACnet has 6 types of communication networks to transmit messages with each defining the physical and data link communication layers. The six network types are:

- BACnet ARCnet
- BACnet Ethernet
- BACnet Lontalk
- BACnet MS/TP
- BACnet Point-to-Point
- BACnet IP

Infitimum Aircore EC+ motors support BACnet MS/TP. BACnet MS/TP utilizes RS485 as the physical layer. RS485 is a serial interface that follows the EIA/TIA-485 standards. Infitimum BACnet operation allows communication baud rates from 9600 to 115200 bits/sec. The interface is a differential signal, electrically isolated. It allows up to 32 devices on a segment, with a maximum cable length of 1000m. This EIA-485 network requires a terminating resistor at each end of the main bus. Infitimum Aircore EC+ motors include the terminating resistor.

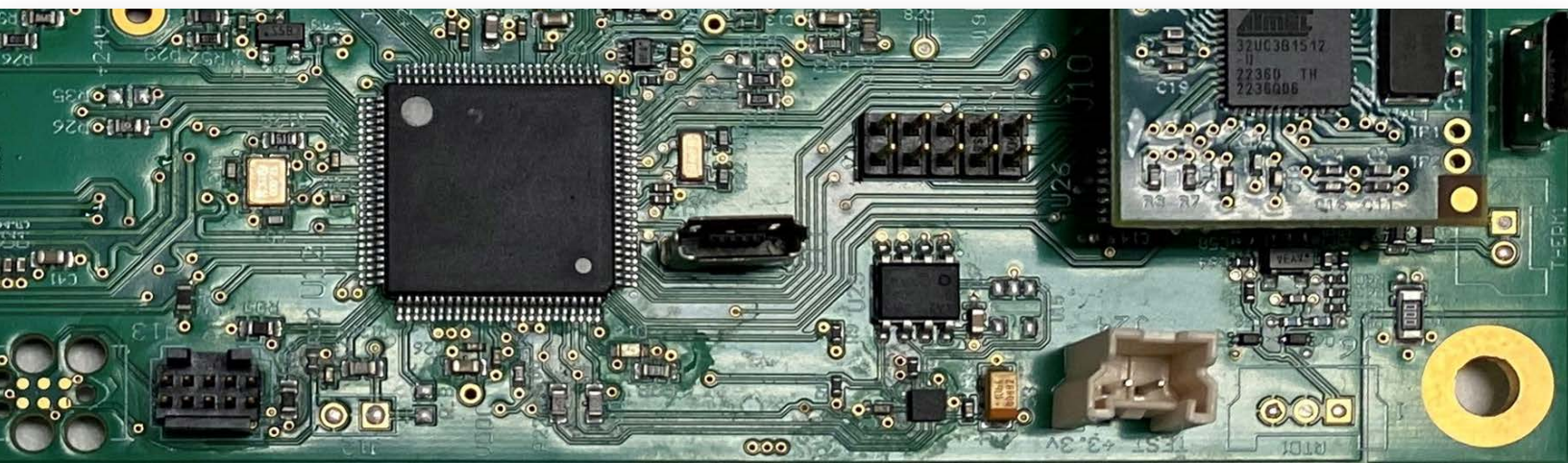

### 3. BACnet: Installation and Field Wiring Hardware

#### BACnet ordering and identification

Infinity Aircore EC+ motors have a catalog number that identifies hardware features of the Aircore EC+ family. Motors are ordered with their features defined by their catalog number. This number is found on the identification label of the motor. The catalog number decoder is below in Figure 1.



Figure 1. BACnet MS/TP is one of the VFD and I/O options (“B”).

#### AE (Aircore EC+) Family Catalog Number **XX-XX-XXXX-XXXX-XXXX**

Family	Frame	Rated Power	Rated Speed	Product Code Voltage	Product Code VFD and I/O	Product Code Reserved	Product Code Bearings	Product Code Shaft Length	Product Code Wireless	Product Code Enclosure	Product Code Grounding
<b>XX</b>	<b>XX</b>	<b>XXXX</b>	<b>XXXX</b>	<b>X</b>	<b>X</b>	<b>X</b>	<b>X</b>	<b>X</b>	<b>X</b>	<b>X</b>	<b>X</b>
AE	13 130 Frame	0590* +	1225 +	A 460V/60Hz	A MODBUS RTU	A None	S Steel	A 3.25"	A None	4 IP54	0 Grounded Wye
	15 150 Frame	0789* +	1800 +	B 415V/60Hz	B BACnet MS/TP		H Hybrid Ceramic		B Bluetooth	5 IP55	3 Delta/HRG
	18 180 Frame	1000* +	2400 +	C* 575V/60Hz					C Cellular		
	20 205 Frame	1500* +	3600 +						W Wi-Fi		

\*0590= 5.9 HP, 0789= 7.89 HP, 1000= 10 HP, 1500= 15 HP

+ More power and speed variations available

### 4. BACnet Module: Installation

BACnet is a factory configured option, though Infinity service technicians can upgrade a field installed motor to support it. BACnet functionality is provided by a BACnet module that is installed on the Aircore EC+ CIM (Communication Interface Module) board.

The BACnet module is BTL certified. [PICS is in appendix.](#)

See Figure 3.

Figure 3. BACnet module

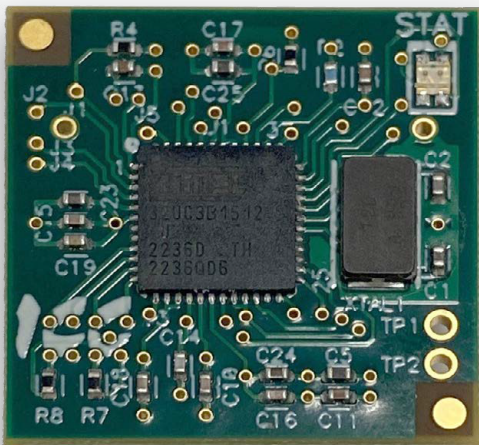

The BACnet module is installed in the CIM below. For reference, the STAT on the screen print on the corner of the BACnet module faces the terminal strip. See Figure 4.

Figure 4. CIM board with BACnet module installed

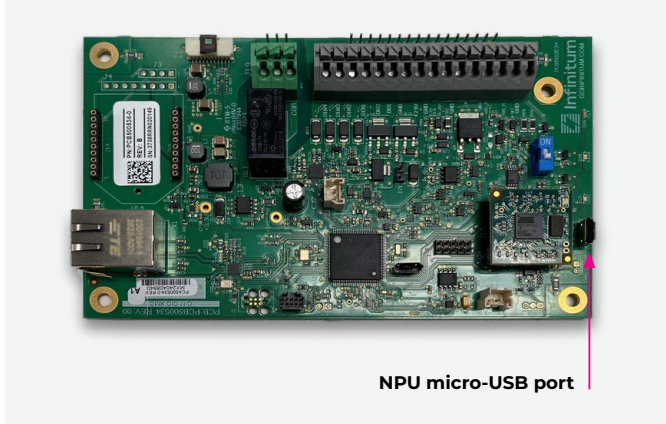

Note: If the BACnet module is installed in the incorrect orientation this could cause permanent damage to the module

## 5. BACnet Module, Field Wiring

Like Modbus, BACnet uses EIA-485 signaling. All control signals are available on the terminal strip of the CIM board. See Figure 5 (Pin label 7) for the EIA-485 connections on the CIM board terminal strip. The following details should be followed for EIA networks:

- Shielded cables should be used with at least one ground wire and twisted signal wires
- Cable runs should be laid separately from power cables if possible
- The network should be grounded, preferably at the same ground connection. Cable shields should be connected at each motor (but not to ground)
- Termination resistance should be provided at each end of the cable run

Figure 5. CIM terminal strip connections

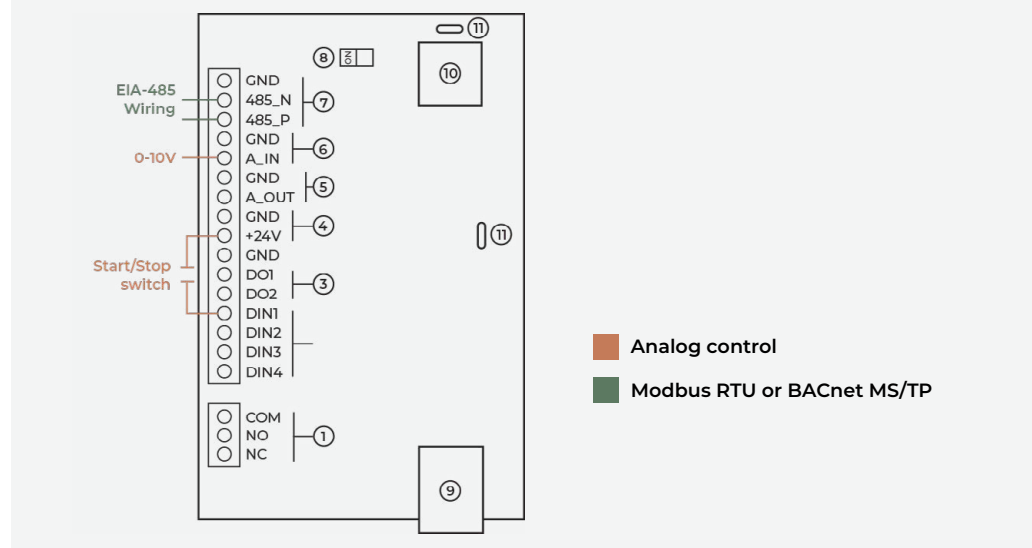

## 6. Terminating Resistor

RS485 based networks require termination at both ends of the main bus. Infinitum motors provide this termination using a DIP switch that connects a 120 Ohm resistor to the serial line. This DIP switch placement is indicated in the drawing in Figure 5 (Identifier 8).

## 7. BACnet Module, Programming

BACnet networks require each device to have a unique address so they can be individually addressed by the BACnet master. Another BACnet parameter that must be established is the Baud rate. Infinitum provides an Installer link to the BACnet Network Parameter Utility (NPU) Tool, which can be used to change the address (Instance) and baud rate of each motor on the BACnet network. The tool is available on the [Infinitum website](#) and as a link on I-con, the Infinitum motor control tool. See Figure 6.

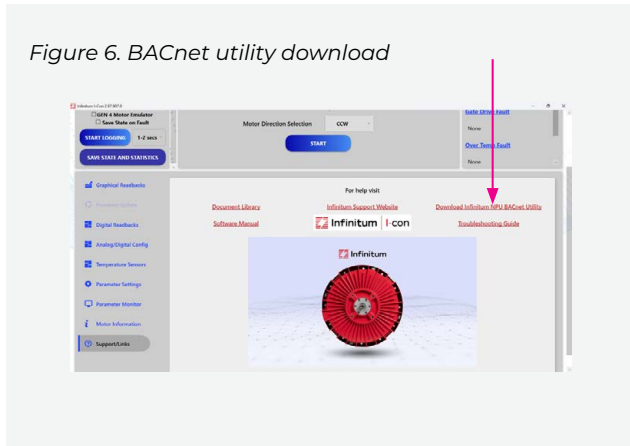

Figure 6. BACnet utility download

Users will need internet access to utilize this link. The link is a Zip file. You should extract all the files then run the NPU.exe file to start the NPU utility.

## 8. NPU Tool

BACnet networks require each device to have a unique address so The Infinitum Network Parameter Utility tool can be downloaded via the links above. Once downloaded, the tool uses a USB connection from a laptop to the CIM board to communicate to the installed BACnet module. See Figure 5. *CIM terminal strip connections* for the location of the Micro-USB port to use with NPU.

Once NPU is downloaded, connect a USB to Micro-USB cable to the port indicated above. Power on the motor and start the NPU program. The screen below should appear, Figure 7.

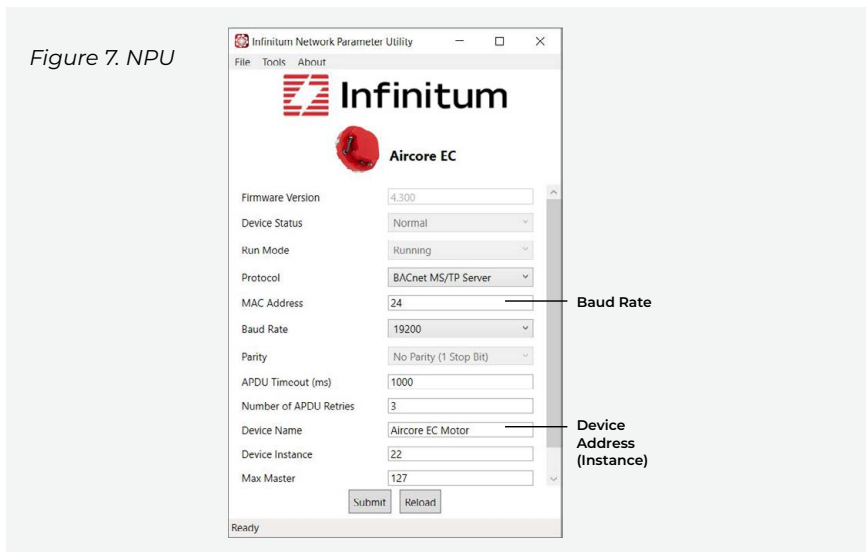

Figure 7. NPU

## 9. BACnet baud rate and address

The baud rate and address (Device Instance) are both editable fields and can be changed with the NPU tool as noted in Figure 7.

Do not alter the MAC address.

Register	Name	BACNet Object Number	BACnet object name (32 characters max)	Qty	BACnet point name (16 characters max)
1001	SW Run/Stop	OBJECT_BINARY_OUTPUT:1	Motor Control	3	Run/Stop Cmd
1002	SW Direction	OBJECT_BINARY_OUTPUT:2			Direction Cmd
1003	SW Speed	OBJECT_ANALOG_OUTPUT:3			Speed Command
1101	Speed User Minimum	OBJECT_ANALOG_OUTPUT:4	Oper Limits	16	Speed User Min
1102	Speed User Maximum	OBJECT_ANALOG_OUTPUT:5			Speed User Max
1103	Speed Absolute Minimum	OBJECT_ANALOG_OUTPUT:6			Speed Abs Min
1104	Speed Absolute Maximum	OBJECT_ANALOG_OUTPUT:7			Speed Abs Max
1105	Acceleration Ramp Duration	OBJECT_ANALOG_OUTPUT:8			Accel Ramp Time
1106	Deceleration Ramp Duration	OBJECT_ANALOG_OUTPUT:9			Decel Ramp Time
1107	Skip Speed 1 Min	OBJECT_ANALOG_OUTPUT:10			Skip Speed 1
1108	Skip Speed 1 Max	OBJECT_ANALOG_OUTPUT:11			Skip Speed 2
1109	Skip Speed 2 Min	OBJECT_ANALOG_OUTPUT:12			Skip Speed 3
1110	Skip Speed 2 Max	OBJECT_ANALOG_OUTPUT:13			Skip Speed BW
1111	Direction Allowed	OBJECT_ANALOG_OUTPUT:14			Dir Allowed
1112	Max Acceleration	OBJECT_ANALOG_INPUT:15			Max Accel Allow
1113	Max Deceleration	OBJECT_ANALOG_INPUT:16			Max Decel Allow
1114	Speed Model Minimum	OBJECT_ANALOG_OUTPUT:17			Speed Model Min
1115	Speed Model Maximum	OBJECT_ANALOG_OUTPUT:18			Speed Model Max
1116	Load Inertia	OBJECT_ANALOG_OUTPUT:19			Load Inertia
1201	Control Mode	OBJECT_ANALOG_OUTPUT:20	Operation Type	10	Control Mode
1202	Speed Input Source	OBJECT_ANALOG_OUTPUT:21			Speed Source
1203	Start/Stop Input Source	OBJECT_ANALOG_OUTPUT:22			Run/Stop Source
1204	Direction Input Source	OBJECT_ANALOG_OUTPUT:23			Dir Source
1205	Clear Fault Input Source	OBJECT_ANALOG_OUTPUT:24			Clr Flt Source
1206	Start Function	OBJECT_ANALOG_INPUT:25			dummy1
1207	Stop Function	OBJECT_ANALOG_INPUT:26			dummy2
1208	Enable Foldback	OBJECT_ANALOG_OUTPUT:27			Enable Foldback
1209	Interlock Input Source	OBJECT_ANALOG_OUTPUT:28			Disable Source
1210	Override Input Source	OBJECT_ANALOG_OUTPUT:29			Override Source
1301	Reset Attempts	OBJECT_ANALOG_OUTPUT:30	Fault Reset	2	Reset Attempts
1302	Reset Delay	OBJECT_ANALOG_OUTPUT:31			Reset Delay
2001	All Function	OBJECT_ANALOG_OUTPUT:32	Term Setting A1	6	All Function
2002	All Minimum Setting	OBJECT_ANALOG_OUTPUT:33			All Min Setting
2003	All Maximum Setting	OBJECT_ANALOG_OUTPUT:34			All Max Setting
2004	All Filter	OBJECT_ANALOG_INPUT:35			dummy3
2005	All Fault Action	OBJECT_ANALOG_INPUT:36			dummy4
2006	All Type Selection	OBJECT_BINARY_OUTPUT:37			All Type Select
2010	All Open Max V	OBJECT_ANALOG_OUTPUT:38	Term Setting A2	6	All Open Max V
2011	All Open Speed RPM	OBJECT_ANALOG_OUTPUT:39			All Open RPM

Register	Name	BACNet Object Number	BACnet object name (32 characters max)	Qty	BACnet point name (16 characters max)
2012	All Stop Min V	OBJECT_ANALOG_OUTPUT:40			All Stop Min V
2013	All Stop Max V	OBJECT_ANALOG_OUTPUT:41			All Stop Max V
2014	All FailOver Stop	OBJECT_BINARY_OUTPUT:42			All FailOv Stop
2015	All FailOver Timeout	OBJECT_ANALOG_OUTPUT:43			All FailOv Tout
2101	DI1 Function	OBJECT_ANALOG_INPUT:44	Term Setting DI	4	DI1 Function
2102	DI2 Function	OBJECT_ANALOG_INPUT:45			DI2 Function
2103	DI3 Function	OBJECT_ANALOG_INPUT:46			DI3 Function
2104	DI4 Function	OBJECT_ANALOG_INPUT:47			DI4 Function
2201	Constant Speed 1	OBJECT_ANALOG_OUTPUT:48	Term Setting CS	5	Const Speed 1
2202	Constant Speed 2	OBJECT_ANALOG_OUTPUT:49			Const Speed 2
2203	Constant Speed 3	OBJECT_ANALOG_OUTPUT:50			Const Speed 3
2204	Constant Speed 4	OBJECT_ANALOG_OUTPUT:51			Const Speed 4
2205	Override Speed	OBJECT_ANALOG_OUTPUT:52			Override Speed
2301	AO1 Function	OBJECT_ANALOG_OUTPUT:53	Term Setting AO	5	AO1 Function
2302	AO1 Scaling Minimum	OBJECT_ANALOG_OUTPUT:54			AO1 Scaling Min
2303	AO1 Scaling Maximum	OBJECT_ANALOG_OUTPUT:55			AO1 Scaling Max
2304	AO1 Filter	OBJECT_ANALOG_OUTPUT:56			AO1 Filter
2305	AO1 Type	OBJECT_BINARY_OUTPUT:57			AO1 Type
2401	DO1 Function	OBJECT_ANALOG_OUTPUT:58	Term Setting DO	2	DO1 Function
2402	DO2 Function	OBJECT_ANALOG_OUTPUT:59			DO2 Function
3001	DC Bus Voltage	OBJECT_ANALOG_INPUT:60	Monitor Env	6	DC Bus Voltage
3002	DC Bus Current	OBJECT_ANALOG_INPUT:61			DC Bus Current
3003	DC Bus Power	OBJECT_ANALOG_INPUT:62			DC Bus Power
3004	Average Current	OBJECT_ANALOG_INPUT:63			Avg Current
3005	Input RMS current	OBJECT_ANALOG_INPUT:64			Inp RMS Current
3006	Input RMS voltage	OBJECT_ANALOG_INPUT:65			Inp RMS Voltage
3101	Stator (RTD)	OBJECT_ANALOG_INPUT:66	Monitor Temp	7	Temp RTD
3102	Stator Average	OBJECT_ANALOG_INPUT:67			Temp Average
3103	T3 HeatSink	OBJECT_ANALOG_INPUT:68			Temp Heatsink
3104	T2 Stator NTC1	OBJECT_ANALOG_INPUT:69			Temp NTC1
3105	INV Board Temp	OBJECT_ANALOG_INPUT:70			Temp INV Board
3106	T1 INV J7 (spare)	OBJECT_ANALOG_INPUT:71			Spare1
3107	T4 Stator NTC2	OBJECT_ANALOG_INPUT:72			Temp NTC2
3114	T14 CIM Board temp	OBJECT_ANALOG_INPUT:73	CIM Temp	1	Temp CIM
3301	Run/Stop Actual	OBJECT_BINARY_INPUT:74	Actual	3	Run/Stop Actual
3302	Direction Actual	OBJECT_BINARY_INPUT:75			Dir Actual
3303	Speed_krpm	OBJECT_ANALOG_INPUT:76			Speed Actual
3501	AIN1	OBJECT_ANALOG_INPUT:77	Analog In %	2	All Value
3502	AIN1 Raw	OBJECT_ANALOG_INPUT:78	Analog in Raw		All Raw
3601	AOUT1	OBJECT_ANALOG_INPUT:79	Analog Out	1	AO1 Value
3701	DIN1	OBJECT_BINARY_INPUT:80	Data Inputs	4	DI1 Value
3702	DIN2	OBJECT_BINARY_INPUT:81			DI2 Value
3703	DIN3	OBJECT_BINARY_INPUT:82			DI3 Value
3704	DIN4	OBJECT_BINARY_INPUT:83			DI4 Value

Register	Name	BACNet Object Number	BACnet object name (32 characters max)	Qty	BACnet point name (16 characters max)
3801	DOUT1	OBJECT_BINARY_INPUT:84	Data Outputs	2	DO1 Value
3802	DOUT2	OBJECT_BINARY_INPUT:85			DO2 Value
4001	Active Faults	OBJECT_BINARY_INPUT:86	Faults	4	Active Faults
4002	Active Warnings	OBJECT_BINARY_INPUT:87			Active Warnings
4003	Clear Faults	OBJECT_BINARY_OUTPUT:88			Clear Faults
4004	Clear Warnings	OBJECT_BINARY_OUTPUT:89			Clear Warnings
4011	Fault Word	OBJECT_ANALOG_INPUT:90	Raw Faults	1	Fault Word
4021	Warning Word	OBJECT_ANALOG_INPUT:91	Warning Word	1	Warning Word
7001	Parameter Table Version	OBJECT_ANALOG_INPUT:92	Parameters	14	Parameter Table
7002	max current	OBJECT_ANALOG_INPUT:93			Motor Max Amps
7003	Motor Voltage	OBJECT_ANALOG_INPUT:94			Motor Voltage
7004	New SN1	OBJECT_ANALOG_INPUT:95			Motor SN 1
7005	New SN2	OBJECT_ANALOG_INPUT:96			Motor SN 2
7006	New SN3	OBJECT_ANALOG_INPUT:97			Motor SN 3
7007	New SN4	OBJECT_ANALOG_INPUT:98			Motor SN 4
7008	New SN5	OBJECT_ANALOG_INPUT:99			Motor SN 5
7009	New SN6	OBJECT_ANALOG_INPUT:100			Motor SN 6
7010	New SN7	OBJECT_ANALOG_INPUT:101			Motor SN 7
7011	Old SN1	OBJECT_ANALOG_INPUT:102			Motor SN 8
7012	Old SN2	OBJECT_ANALOG_INPUT:103			Motor SN 9
7013	Old SN3	OBJECT_ANALOG_INPUT:104			Motor SN 10
7014	Old SN4	OBJECT_ANALOG_INPUT:105			Motor SN 11
7021	Model	OBJECT_ANALOG_INPUT:106	Model	2	Motor Model
7022	Motor rated speed	OBJECT_ANALOG_INPUT:107			Motor rated RPM
7031	INV FW Major	OBJECT_ANALOG_INPUT:108	Motor ID	14	INV FW Major
7032	INV FW Minor	OBJECT_ANALOG_INPUT:109			INV FW Minor
7033	CIM FW Major	OBJECT_ANALOG_INPUT:110			CIM FW Major
7034	CIM FW Minor	OBJECT_ANALOG_INPUT:111			CIM FW Minor
7035	Motor Type	OBJECT_ANALOG_INPUT:112			Motor Type
7036	Hardware ID	OBJECT_ANALOG_INPUT:113			Hardware ID
7037	INV FW Patch	OBJECT_ANALOG_INPUT:114			INV FW Patch
7038	CIM FW Patch	OBJECT_ANALOG_INPUT:115			CIM FW Patch
7039	Hardware ID INV	OBJECT_ANALOG_INPUT:116			Hardware ID INV
7040	Hardware ID VFD	OBJECT_ANALOG_INPUT:117			Hardware ID VFD
7041	Hardware ID CIM	OBJECT_ANALOG_INPUT:118			Hardware ID CIM
7042	Horsepower	OBJECT_ANALOG_INPUT:119			Horsepower
7043	Frame Size	OBJECT_ANALOG_INPUT:120			Frame Size
7044	Stator type	OBJECT_ANALOG_INPUT:121			Stator Type
7101	Drive Runtime hours	OBJECT_ANALOG_INPUT:122	Runtime	3	Drive Runtime
7102	Motor Runtime hours	OBJECT_ANALOG_INPUT:123			Motor Runtime
7103	Motor Energy megawatt-hours	OBJECT_ANALOG_INPUT:124			Motor MWh
8701	Parameter Save	OBJECT_ANALOG_OUTPUT:125	Parameter Save	1	Parameter Save

## 10. Appendix & Troubleshooting

# Appendix

Infinitem BACnet Protocol Implementation Conformance Statement (PICS)

[PICS-downloadable.PDF](#)

### Aircore EC Com Module - BACnet PICS

#### BACnet Protocol Implementation Conformance Statement (PICS)

Date: June 26, 2024  
Vendor Name: Infinitem, Inc.  
Product Name: Aircore EC Com Module  
Product Model Number: BACnet  
Application Software Version: V4.300  
Firmware Revision: V4.300  
BACnet Protocol Revision: 12

#### Product Description:

The AirPort is a miniature serial communications engine-on-module for BACnet MS/TP applications. This product supports native BACnet, connecting directly to the MS/TP LAN using 19200 baud rate. The device can be configured as a BACnet Server.

#### BACnet Standard Device Profile (Annex L):

- BACnet Operator Workstation (B-OWS)
- BACnet Building Controller (B-BC)
- BACnet Advanced Application Controller (B-AAC)
- BACnet Application Specific Controller (B-ASC)
- BACnet Smart Sensor (B-SS)
- BACnet Smart Actuator (B-SA)

#### BACnet Interoperability Building Blocks Supported (Annex K):

- Data Sharing – ReadProperty-A (DS-RP-A)
- Data Sharing – ReadProperty-B (DS-RP-B)
- Data Sharing – ReadPropertyMultiple-B (DS-RPM-B)
- Data Sharing – WriteProperty-A (DS-WP-A)
- Data Sharing – WriteProperty-B (DS-WP-B)
- Data Sharing – WritePropertyMultiple-B (DS-WPM-B)
- Data Sharing – COV-B (DS-COV-B)
- Device Management – Dynamic Device Binding-A (DM-DDB-A)
- Device Management – Dynamic Device Binding-B (DM-DDB-B)
- Device Management – Dynamic Object Binding-B (DM-DOB-B)
- Device Management – DeviceCommunicationControl-B (DM-DCC-B)
- Device Management – ReinitializeDevice-B (DM-RD-B)
- Device Management – TimeSynchronization-B (DM-TS-B)\*
- Device Management – UTCTimeSynchronization-B (DM-UTC-B)\*

\* Available only when Real-time Clock Settings are enabled

#### Segmentation Capability:

- Able to transmit segmented messages Window Size \_\_\_\_\_
- Able to receive segmented messages Window Size \_\_\_\_\_

Standard Object Types Supported:

Property	Object Type									
	Device	Binary Input	Binary Output	Binary Value	Analog Input	Analog Output	Analog Value	Multi-state Input	Multi-state Output	Multi-state Value
Object Identifier	W	R	R	R	R	R	R	R	R	R
Object Name	W	R	R	R	R	R	R	R	R	R
Object Type	R	R	R	R	R	R	R	R	R	R
System Status	R									
Vendor Name	R									
Vendor Identifier	R									
Model Name	R									
Firmware Revision	R									
Application Software Version	R									
Protocol Version	R									
Protocol Revision	R									
Protocol Services Supported	R									
Protocol Object Types Supported	R									
Object List	R									
Max APDU Length Accepted	R									
Segmentation Supported	R									
Local Time*	W									
Local Date*	W									
UTC Offset*	W (-840... 720)									
Daylight Savings Status*	W									
APDU Timeout	W (10... 65535)									
Number Of APDU Retries	W (0... 10)									
Max Master	W (1... 127)									
Max Info Frames	W (1... 100)									
Device Address Binding	R									
Database Revision	R									
Active COV Subscriptions	R									
Present Value		R	W	W	R	W	W	R	W	W
Status Flags		R	R	R	R	R	R	R	R	R
Event State		R	R	R	R	R	R	R	R	R
Reliability		R	R	R	R	R	R	R	R	R
Out Of Service		R	R	R	R	R	R	R	R	R
Number Of States								R	R	R

<b>Units</b>					R	R	R			
<b>Priority Array</b>			R	R		R	R		R	R
<b>Relinquish Default</b>			R	R		R	R		R	R
<b>COV Increment</b>					W	W	W			
<b>Polarity</b>		W	W							
<b>Inactive Text</b>		R	R	R						
<b>Active Text</b>		R	R	R						

R – Readable using BACnet services

W – Readable and writable using BACnet services

\* Available only when Real-time Clock Settings are enabled

#### Data Link Layer Options:

- BACnet IP, (Annex J)
- BACnet IP, (Annex J), Foreign Device
- ISO 8802-3, Ethernet (Clause 7)
- ANSI/ATA 878.1, 2.5 Mb. ARCNET (Clause 8)
- ANSI/ATA 878.1, RS-485 ARCNET (Clause 8), baud rate(s) \_\_\_\_\_
- MS/TP master (Clause 9), baud rate(s): 19200
- MS/TP slave (Clause 9), baud rate(s): \_\_\_\_\_
- Point-To-Point, EIA 232 (Clause 10), baud rate(s): \_\_\_\_\_
- Point-To-Point, modem, (Clause 10), baud rate(s): \_\_\_\_\_
- LonTalk, (Clause 11), medium: \_\_\_\_\_
- Other: \_\_\_\_\_

#### Device Address Binding:

Is static device binding supported? (This is currently for two-way communication with MS/TP slaves and certain other devices.)  Yes  No

#### Networking Options:

- Router, Clause 6 - List all routing configurations
- Annex H, BACnet Tunneling Router over IP
- BACnet/IP Broadcast Management Device (BBMD)
  - Does the BBMD support registrations by Foreign Devices?  Yes  No

#### Network Security Options:

- Non-secure Device - is capable of operating without BACnet Network Security
- Secure Device - is capable of using BACnet Network Security (NS-SD BIBB)
  - Multiple Application-Specific Keys:
  - Supports encryption (NS-ED BIBB)
  - Key Server (NS-KS BIBB)

## Character Sets Supported:

Indicating support for multiple character sets does not imply that they can all be supported simultaneously.

- |   |   |                                     |
|---|---|-------------------------------------|
| <input checked="" type="checkbox"/> ISO 10646 (UTF-8) | <input type="checkbox"/> IBM™/Microsoft™ DBCS | <input type="checkbox"/> JIS X 0208 |
| <input type="checkbox"/> ISO 10646 (UCS-4)            | <input type="checkbox"/> ISO 10646 (UCS-2 )   | <input type="checkbox"/> ISO 8859-1 |

If this product is a communication gateway, describe the types of non-BACnet equipment/networks(s) that the gateway supports:

Refer to protocol-specific manuals for other supported protocols.



We reserve the right to make technical changes or modify the contents of this document without prior notice. 2026 Infinitum Electric, Inc. All rights reserved.

**Office**  
12234 N IH 35 SB  
Building B  
Austin, TX 78753

**Contact**  
[info@goinfinitum.com](mailto:info@goinfinitum.com)  
[goinfinitum.com](http://goinfinitum.com)  
[support.goinfinitum.com](http://support.goinfinitum.com)