

Aircore EC

Installation, Operation, & Maintenance Manual

Release: Gen 4
Date: October, 2025



Table of contents

| | | | |
|---|----------|---|-----------|
| 1. About the manual | 3 | 5. Motor maintenance | 11 |
| a. Warnings, cautions and notes | 3 | a. Maintenance tasks | 11 |
| 2. Motor technology | 3 | b. Mechanical | 11 |
| a. Motor overview | 3 | 6. Motor operations | 11 |
| i. Aircore EC motor technology | 3 | a. Windmilling | 11 |
| ii. Infinitum Aircore EC stator | 3 | 7. Motor drive parameters and data types | 12 |
| iii. Aircore EC motor components | 3 | 8. Related documents | 12 |
| 3. Receiving inspection and storage | 4 | 9. Appendix & troubleshooting | 13 |
| a. Packing inspection | 4 | | |
| b. Remove motor from container | 4 | | |
| c. Compare nameplate data | 4 | | |
| d. Catalog number decoder | 5 | | |
| e. Rotate motor output shaft | 5 | | |
| f. Ready spare storage | 5 | | |
| i. Motor bearings | 5 | | |
| ii. Scheduled output shaft rotation | 5 | | |
| 4. Motor installation | 6 | | |
| a. Preparation | 6 | | |
| i. Operating ambient temperature | 6 | | |
| ii. Ingress protection | 6 | | |
| b. Motor location | 6 | | |
| c. Motor Orientation | 6 | | |
| d. Motor mounting and alignment | 6 | | |
| i. Mounting options | 6 | | |
| ii. Peripheral mounting block | 6 | | |
| iii. C-face mounting | 7 | | |
| e. Mounting and aligning motor | 7 | | |
| f. Minimum motor connection requirements | 7 | | |
| g. Motor control connections | 8 | | |
| h. Motor ground circuit verification | 8 | | |
| i. Grounding | 8 | | |
| j. Connecting motor | 8 | | |
| k. Conductor size and terminal data | 9 | | |
| l. Circuit breaker and wire sizing | 9 | | |
| Table 1: Breakers and fuses | 9 | | |
| Table 2: Terminal connection data | 9 | | |
| m. Control connections | 10 | | |
| n. Analog control wire guidelines | 10 | | |
| o. Modbus RTU or BACnet MS/TP wiring guidelines | 10 | | |
| p. AC main input connections | 10 | | |
| q. LED operation | 11 | | |
| r. Check motor rotation | 11 | | |
| s. Connect motor to driven equipment | 11 | | |
| t. Default and user programmable settings | 11 | | |

1. About the manual

a. Warnings, cautions and notes

Warnings, cautions and notes are throughout the manual to alert the technician of potential hazard or process information.

Below is an explanation of the use.

⚠ *Warnings: are safety related. Serious injury, death and equipment damage can result if the instructions in the warning are not followed.*

Cautions: apply to conditions that can cause equipment damage. If instructions in the Caution are not followed, motor and associated equipment damage may occur.

Notes: The text of the note is italicized. Notes add information that can aid in the completion of a process or step.

2. Motor technology

a. Motor overview

Infinitem has developed a new generation of electric motors with unparalleled efficiency and durability. We've reinvented axial air-core motors using lightweight materials and a modular design that generates the same power with less weight than a legacy motor. These motors include an optimized VFD (Variable Frequency Drive) for maximum performance and efficiency at a wide operating range. Infinitem has an established ecosystem of configuration software for real-time monitoring and analytics. These motors are manufactured at a fraction of the carbon footprint created by conventional motors. It is designed with future generations in mind taking the entire lifecycle into account creating a huge leap in sustainability.

i. Aircore EC motor technology

The introduction of the Aircore EC motor surpasses motors utilizing standard technology and construction. Like all motors, Infinitem machines have a stator, the stationary part and a rotor. The rotating component of Aircore EC motors is two rotors. In traditional motors the stator is located in the body of the motor and is usually made of iron cores with copper windings. This iron and copper adds to the overall weight of the motor. Additionally, the insulation on these coil windings degrades with heat and time requiring maintenance or eventual replacement of the motor.

ii. Infinitem Aircore EC stator

The Aircore EC stator is a Printed Circuit Board (PCB) rather than utilizing a heavy iron core and with copper windings. The Infinitem motor is designed utilizing a PCB stator sandwiched between two rotors (Figure 1). Permanent magnets are attached to the surface of the two rotors. Since there is no iron in the magnetic path, the motors is classified as an air-core design.

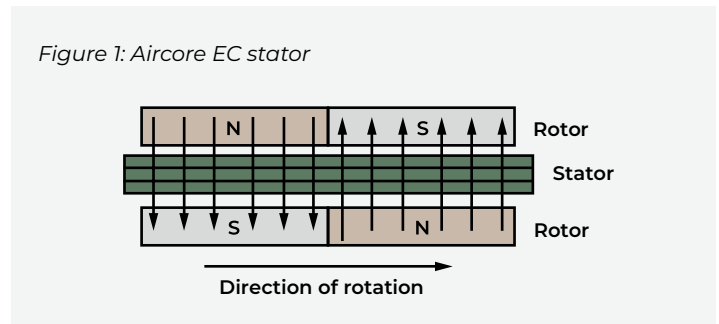

iii. Aircore EC motor components

The PCB stator design allows for a smaller motor that weighs significantly less than a conventional motor. Key components are identified by the drawing in Figure 2.

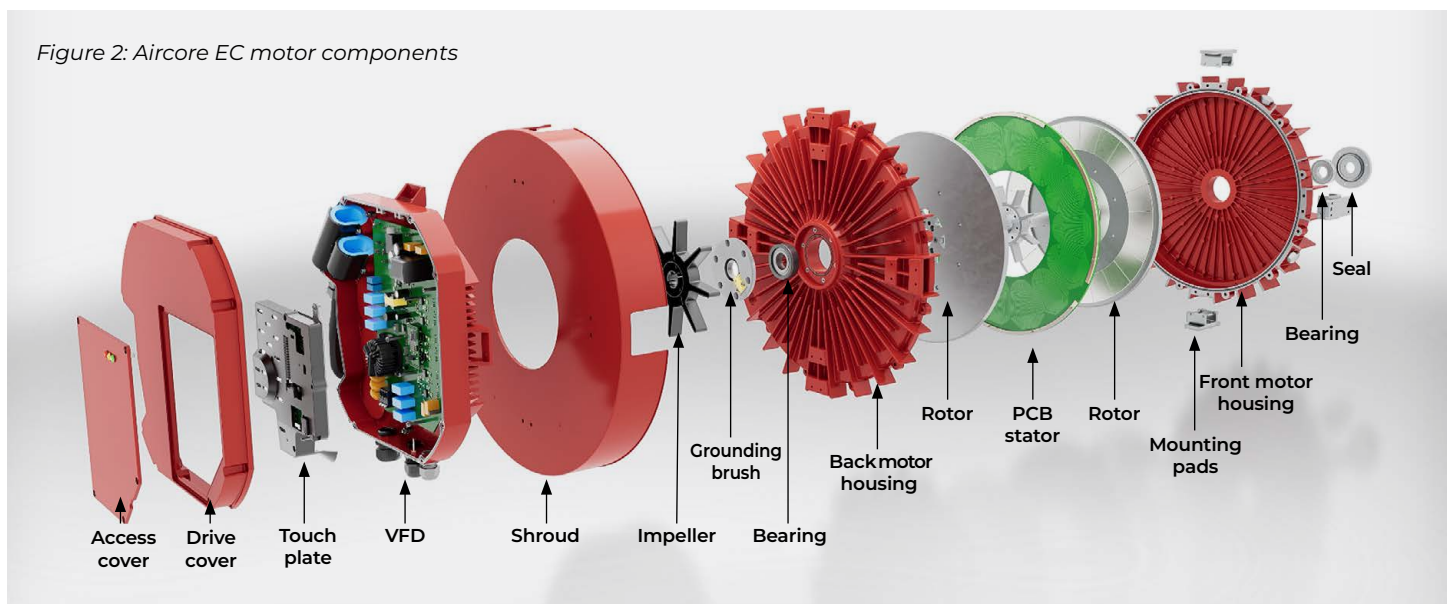

3. Receiving inspection and storage

Review all appropriate sections prior to motor installation. The motor is shipped in one or four motor palletized container. The container and motor can be moved by using a dolly, pallet jack or fork truck (Figure 3).

a. Packing inspection

Inspect the motor packing for damages during shipping. If the package is damaged, remove the packing and inspect the motor for damage. Motor damage from shipping must be reported to shipper.

b. Remove motor from container

⚠ Warning: The motor is provided with two mounting brackets with threaded holes for a lifting lug. Lifting lugs may or may not be shipped with the motor. The lugs are intended to lift the motor assembly only. Attaching the component it drives will exceed the design weight limits. To reduce the possibility of personal injury or death lift the motor only, make sure the lugs are completely threaded into the brackets, and ensure they do not rotate out during lifting. Lifting eye-bolts are M10x1.5t thread, 20mm shank or 1/2"-13 thread, 1 1/2" shank length, depending on motor. Consult the appropriate drawing for that motor to be sure. **Warning:** To reduce the possibility of personal injury and equipment damage, only use a lifting device and straps that are rated for the motor weight. Do not lift the motor without mechanical assistance. Always inspect straps for damages and weight certification prior to use.

Remove top of the packing crate (Figure 3) and foam next to the two mounting brackets and install the supplied lifting lugs (Figure 4). Make sure the lugs are threaded completely into the motor housing. Use an approved lifting device to remove the motor from the packing crate. To use peripheral mount two additional brackets should be ordered (Figure 4). The attachment screws should be torqued to 140 in-lbs.

Figure 3: packing crate



Figure 4: mounting bracket



c. Compare nameplate data

- Compare data on nameplate (Figure 5) with purchase order to verify receipt of proper motor. Labels are on the motor shroud.
- Compare data on nameplate for desired power supply and control equipment requirements.

Figure 5: nameplate

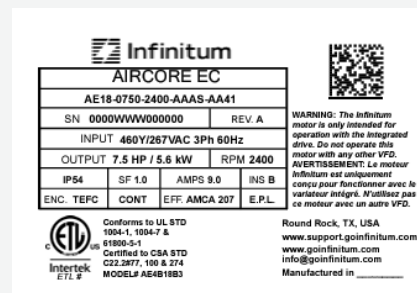

d. Catalog number decoder

Infinity Aircore EC motors are ordered with a catalog numbers using the following decoder scheme. (Figure 6)

Figure 6: catalog number

AE (Aircore EC) Family Catalog Number XX-XX-XXXX-XXXX-XXXX

| Family | Frame | Rated Power | Rated Speed | Product Code Voltage | Product Code VFD and I/O | Product Code Reserved | Product Code Bearings | Product Code Shaft Length | Product Code Wireless | Product Code Enclosure | Product Code Grounding |
|--------|--------------|-------------|-------------|----------------------|--------------------------|-----------------------|-----------------------|---------------------------|-----------------------|------------------------|------------------------|
| XX | XX | XXXX | XXXX | X | X | X | X | X | X | X | X |
| AE | 13 130 Frame | 0590* + | 1225 + | A 460V/60Hz | A MODBUS RTU | A None | S Steel | A 3.25" | A None | 4 IP54 | 0 Grounded Wye |
| | 15 150 Frame | 0789* + | 1800 + | B 415V/60Hz | B BACnet MS/TP | | H Hybrid Ceramic | | B Bluetooth | 5 IP55 | 3 Delta/HRG |
| | 18 180 Frame | 1000* + | 2400 + | C* 575V/60Hz | | | | | C Cellular | | |
| | 20 205 Frame | 1500* + | 3600 + | | | | | | W Wi-Fi | | |

*0590= 5.9 HP, 0789= 7.89 HP, 1000= 10 HP, 1500= 15 HP

+ More power and speed variations available

e. Rotate motor output shaft

⚠ Warning: The rotor in this motor incorporates a Permanent Magnet (PM) design. When the rotor is rotated a voltage is produced in the stator even when the motor is disconnected from a power source. Do not open electrical compartments or touch unprotected terminals while the rotor is turning. Disconnect motor supply power and allow one minute for capacitors to discharge before servicing or replacing. Failure to comply with rotor safety procedures can cause serious injury or death and equipment damage.

Make sure all motor wire connections are properly terminated and insulated. Turn motor rotor (output shaft) by hand. It should turn freely with some drag from the bearing seals.

f. Ready spare storage

Motors purchased for ready spares are not placed into service immediately. These motors should be stored in a clean, dry space. Avoid spaces with large temperature swings to reduce condensation. Storage temperature is -40 to 185 °F (-40 to 85 °C).

Cover motors to prevent airborne dust and dirt particles. If storage area location is prone to vibration, place vibration dampers under motor base to prevent premature wear and damage to bearings.

i. Motor bearings

The bearings (Figure 7) used in this motor are lubricated and sealed at the factory. The motor does not require bearing lubrication in the field or during storage.

ii. Scheduled output shaft rotation

⚠ Warning: The rotor in this motor incorporates a Permanent Magnet (PM) design. When the rotor is rotated a voltage is produced in the stator even when the motor is disconnected from a power source. Do not open electrical compartments or touch unprotected terminals while the rotor is turning. Disconnect motor supply power and allow one minute for capacitors to discharge before servicing or replacing. Failure to comply with rotor safety procedures can cause serious injury or death and equipment damage.

It is recommended the rotor (output shaft) be rotated five to ten times per every quarter (three months). This distributes grease in the bearings and reduces the chance of corrosion formation on bearing rolling elements and raceways. Bearing seals can add some resistance to turning the rotor.

Figure 7: bearings

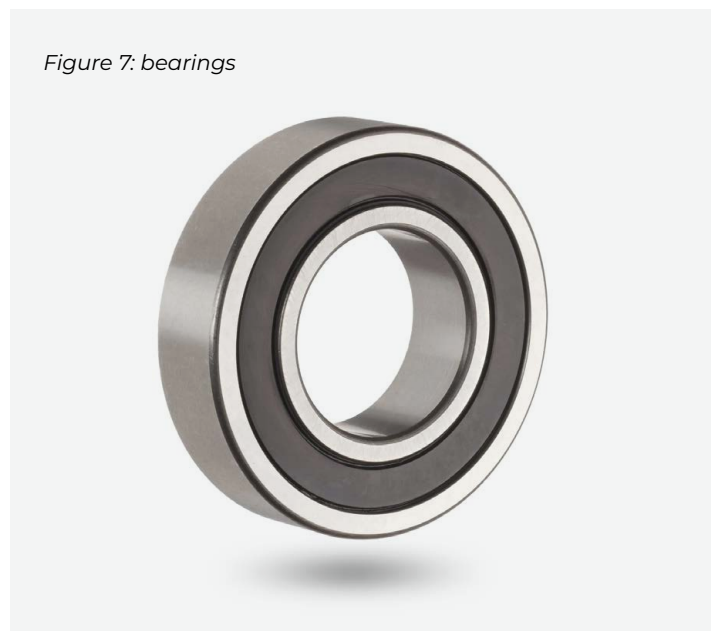

4. Motor installation

a. Preparation

Review this entire manual prior to scheduling the motor installation. All equipment related to systems operation must be secured and have an active LOTO (Lock Out Tag Out) procedure in accordance with application specific safety policies. All users of should be notified of equipment outage.

i. Operating ambient temperature

The ambient temperature of the air supplied to the motor cooling inlet should not exceed 40° C (104° F) or be less than -25° C (-13° F). Power can be derated at higher temperatures by 2% per degree C up to 50° C. Use the Infinitum Motor Selection Tool to confirm derating details. Consult Infinitum for ambient temperatures not within these requirements.

Occasional start-up at temperature below -25C is permitted under certain conditions. For continuous operation at ambient temperatures below -25°C, special low-temperature bearings are required. Contact Infinitum for any application below -25C ambient.

ii. Ingress protection

Infinitum motor Ingress Protection (IP) ratings are identified by their respective nameplates. To maintain this IP rating, cable glands or seals must be used at all wiring ports and all gaskets in place with covers.

b. Motor location

⚠ Warning: *This motor is not certified to operate in any hazardous environments. Operating a motor in areas contaminated with explosive gases can cause explosions resulting in serious injury or death and equipment damage.*

Electric motors have guidelines for the location and operating environment. These guidelines are listed below:

- The motor should be located in a ventilated enclosure and should be in an area that allows air circulation.
- Air cooling inlets and outlets must not be obstructed.
- The enclosure cannot be located in an area with harmful or explosive gasses.
- The area should be free from dust and metallic particles.
- The motor should be easily accessed for cleaning and maintenance.

c. Motor Orientation

Gen4 Aircore EC motors can be used in any orientation, horizontal, shaft up or shaft down.

d. Motor mounting and alignment

The Aircore EC motor system is supplied with an integrated VFD. The motor and drive are the major components of the assembly. Refer to motor [datasheets](#) for detailed dimension drawings.

i. Mounting options

Driven equipment (for example, a fan wheel) should be mounted to the shaft using as much of the available shaft length as possible. A shaft key-way and shaft key are provided for secure coupling of hubs to the shaft.

There are two mounting options for the motor, peripheral mounting or C-face mounting.

ii. Peripheral mounting block

There are four mounting blocks (if ordered) on the surface of the motor, spaced at 90° intervals. Each block has provisions for a lifting lug that can be used to lift the motor, and mounting holes at the drive end (DE) face and transverse surface.

The transverse face of the mounting block has threaded holes for four mounting bolts. All four mounting bolts should be installed for secure motor mounting. See the respective motor diagram for a its mounting hole pattern in Figure 8.

Figure 8: circumference mounting pads and shaft keyway

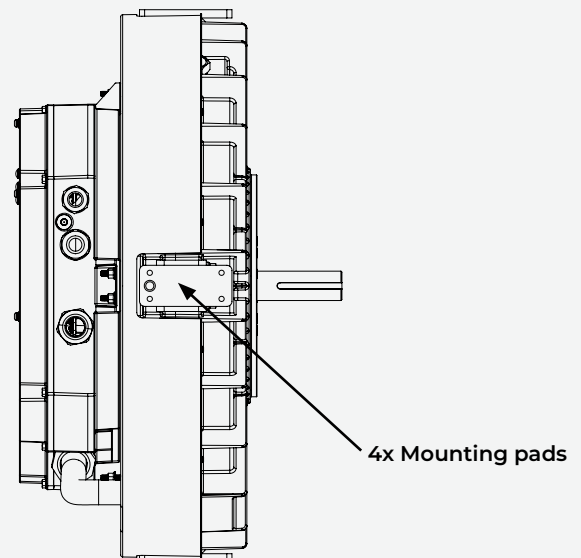

iii. C-face mounting

Infinity Aircore EC motors are not a NEMA standard frame size but utilize a NEMA 182TC faceplate mounting configuration.

The DE face of the mounting block has threaded holes for four bolts (M8X1.25). All bolt holes should be used for secure mounting of the motor to equipment (Figure 9).

Figure 9: DE face

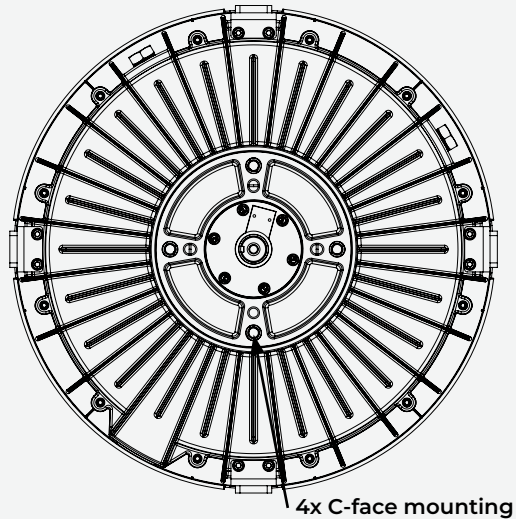

⚠ Caution: Use care when installing the driven equipment onto the rotor shaft. Do not force the hub or coupling onto the shaft since this may damage the motor bearings. If the hub or coupling does not slide without resistance, check alignment of the equipment with the rotor shaft.

Maintain adequate clearance between the front of the motor body and the equipment to prevent mechanical obstruction that may cause damage or injury.

The motor and stator assembly must be mounted on a structure that will support the operational weight of the motor and drive. Using vibration dampers at motor assembly mounts to reduce motor vibration is recommended. Align the motor output shaft centerline with the driven component and install mounting hardware but do not tighten. This is completed with the alignment process.

e. Mounting and aligning motor

The motor may be directly mounted to equipment such as fan wheels or may be connected through a belt or pulley system. It may also be attached through a shaft coupling, e.g., to an independently mounted pump, or to a torque meter in a laboratory setting. Ensure proper alignment is maintained in all arrangements.

Use driven equipment manufacturer's recommendations for aligning the motor with the fan drive or coupling. Tighten all bolts and nuts on the motor mount.

Motor rotation must be verified after electrical connection. Incorrect rotation can damage equipment.

f. Minimum motor connection requirements

⚠ Warning: Always disconnect power to the motor and practice all application specific safety procedures when installing, troubleshooting, or repairing a motor. Always verify power is secured with a multimeter prior to work. Failure to disconnect power from motors can result in serious personal injury or death and equipment damage.

Warning: The rotor in this motor incorporates a Permanent Magnet (PM) design. When the rotor is rotated in a disconnected motor voltage is produced. Do not touch unprotected terminals while the rotor is turning. Disconnect motor supply power and allow one minute for capacitors to discharge before servicing or replacing. Failure to comply with rotor safety procedures can cause serious injury or death and equipment damage.

Warning: To reduce the possibility of personal injury or death and equipment damage, always make sure wire connections are secure and wires are in the correct location.

Caution: To prevent the possibility of motor damage, always use terminating ferrules for all supply wires. Terminating ferrules create a single connection point that is more secure than stranded wire.

Wire tensile forces can affect the point of termination during installation and motor operation. Terminal blocks with the correct wiring installed ensure safe motor operation. Using the correct wire gauge and amount of exposed conductor length with ferrules installed on each wire satisfies the requirements.

Make sure the source of power to the motor has been disconnected.

Strip wires and crimp on wire ferrules. Install each wire into the appropriate terminal block as provided in the wiring instructions. Verify all connections are tight and installed to specifications.

NEC 70 and NEMA MG2 standards should be followed for proper motor power wiring.

g. Motor control connections

Infinitem Aircore EC motors support standard industry control methods. The following are supported:

- Analog
- Modbus RTU
- BACnet MS/TP
- Modbus TCP for I-con

Infinitem supplies proprietary configuration and control software known as [I-con \(motor control software\)](#).

h. Motor ground circuit verification

⚠ Warning: Motors must be properly grounded. Adhere to all guidelines when installing the motor ground circuit. Failure to ground a motor can cause personal injury, death, and equipment damage.

It is advised to conduct resistance readings with a multimeter on the motor ground circuit. Never apply power to a motor that does not have a complete ground circuit.

i. Grounding

Infinitem Aircore EC motors can be installed in a Grounded Wye or Delta/HRG (High Resistance Ground) topology. Both are identified by their respective Catalog (ordering) number.

j. Connecting motor

Each of the circuit boards and housing components has a separate design function. Only two of the circuit boards have user inputs. The main circuit boards and connection points are highlighted in Figure 10.

1. Power board: Connections for three-phase supply. Rectifiers convert AC to DC for internal use on this board.
2. Control interface module (CIM). This circuit board contains advanced controls and communications.
3. AC Input: Ground terminal is in the chassis. (Figure 10)

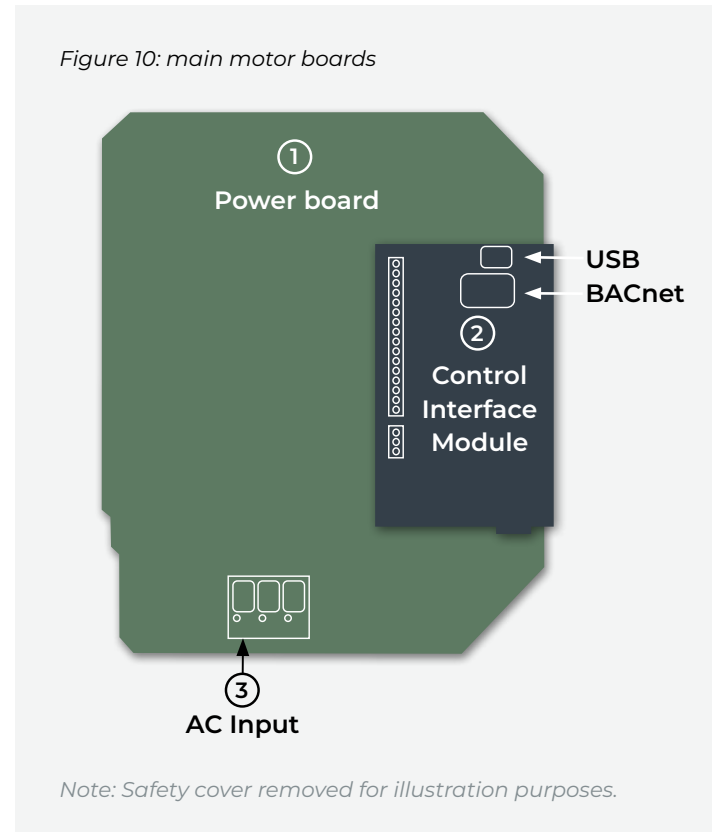

k. Conductor size and terminal data

| Board | Terminals | Maximum conductor size | | Exposed conductor length | Terminal type |
|--------------------------------|-------------------|------------------------|---------|--------------------------|----------------------------------|
| | | mm ² | AWG | | |
| Communication interface module | Control terminals | 1.3 | 16 | 8 mm | Spring terminal |
| Power board | AC Mains-U, V & W | 5.2 / 3.3 | 10 / 12 | 12 mm | Spring terminal |
| Screw terminal | Earth ground | 1.6 | 14 | 12 mm | Lug and screw Max torque 2 Nm |

I. Circuit breaker and wire sizing

Short circuit protection should be provided to protect the input power conductors. UL and/or CSA (as required by local regulations) approved fuses (such as class CC or class J) or circuit breakers (UL 489) should be used and sized in accordance with applicable regulations or Table 1.

The supply conductors should be sized based on the current requirements of the motor. The connector minimum and maximum wire sizes are included in Table 2.

Overload protection is required for Infinitum motors marked as "Electronically Protected L." UL and/or CSA (as required by local regulations) approved motor overload protectors should be used and set as required by local regulations. Combination motor controllers, such as UL Type E controllers, when used as intended may be used to provide disconnect, short circuit protection, and overload protection in the same device.

The maximum permissible short circuit current at the drive input power terminals is 5kA.

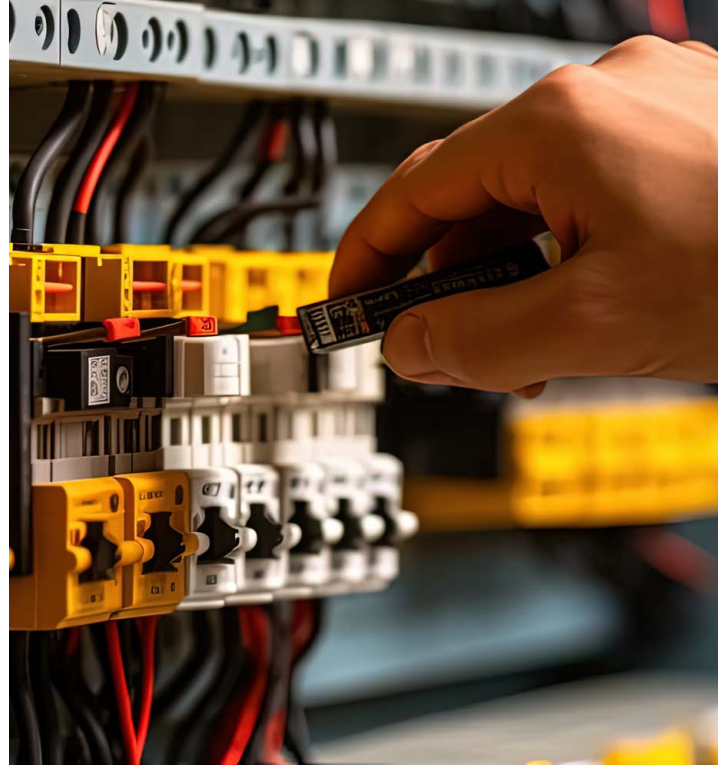

Table 1: Breakers and fuses (3-phase 460V AC (+/- 10%) – 3-phase 460V output)

| Power (HP) | Rated current (A) | Listed/Certified fuses or breakers | Minimum suggested wire size (AWG) |
|------------|-------------------|------------------------------------|-----------------------------------|
| 5 | 6.0 | 10 | 16 |
| 7.5 | 9.0 | 15 | 16 |
| 10 | 12.0 | 15 | 14 |
| 15 | 17.0 | 25 | 12 |

Table 2: Terminal connection data

| | min. | max. |
|---|---------------------|-------------------|
| Rigid cable cross-section | 0.2 mm ² | 6 mm ² |
| Flexible cable cross-section | 0.2 mm ² | 6 mm ² |
| Cross section AWG | 24 | 10 |
| Wire-end ferrules (w/insulating collar) | 0.2 mm ² | 4 mm ² |

m. Control connections

Remove the VFD cover for access to Analog/Digital, Modbus and (optional) BACnet connections.

1. Relay (1) – NO / NC (COM must be used)
 - Max voltage: 125 VAC / 30 VDC
 - Max current: NO-10A VAC, 5 A
 - VDC: NC – 3A VAC or VDC
2. Digital input (4) – DIN1, DIN2, DIN3, DIN4
3. Digital output (2) – DO1 & DO2
 - Open drain output
- ⚠ 4. Max switching voltage: 40 VDC
- Max switching current: 350 mA
4. Auxiliary voltage (1) – +24V (GND must be used), 250 mA max
5. Analog output (1) – A_OUT (GND must be used) 10 V, 10 mA max
6. Analog input (1) – A_IN (GND must be used)
7. EIA-485 interface (1) – 485_P & 495_N (Modbus RTU or BACnet MS/TP)

Note: Use wirenut to connect shield wires. Do not tie to GND.

8. EIA-485 termination switch. (Default is Off)
9. RJ45 (ethernet) for I-con (motor control software) connection
10. Optional BACnet module
11. USB

Terminals on the interface board (Figure 11) feature push-button spring clips. The push-button on each terminal must be depressed while inserting the wire. Releasing the push-button clips the wire into place.

n. Analog control wire guidelines

To control the unit using Analog control please utilize the wiring guidelines on the CIM board (Figure 11).

o. Modbus RTU or BACnet MS/TP wiring guidelines

To control the motor with Modbus RTU or BACnet MS/TP please utilize the wiring guidelines to connect to the Communication I/O (Figure 11).

- The last unit on a daisy-chain Modbus RTU or BACnet MS/TP configuration should have the EIA-485 Termination DIP switch “ON”.
- All other units must have the DIP switch in the “OFF” position.
- Modbus RTU operation requires changes to the motor configuration parameters for slave address
- BACnet MS/TP operation requires changes to the Device Instance field to establish it unique BACnet identifier.

Figure 11: CIO board

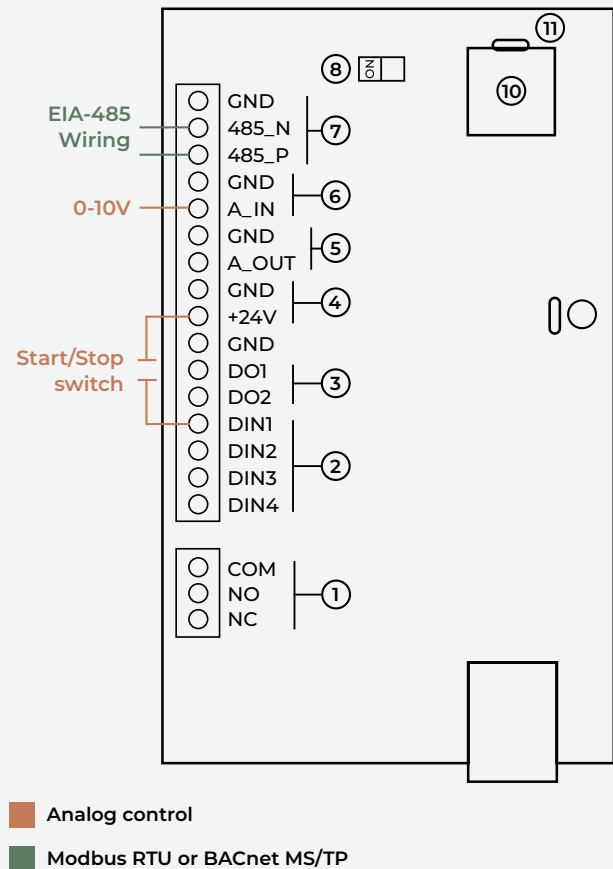

p. AC main input connections

The AC main inputs (Figure 11) are on the power board.

The supply voltage connections are:

1. Supply voltage phase A
2. Supply voltage phase B
3. Supply voltage phase C

The AC input terminals feature spring clips. The orange tab must be raised to insert the wire. Closing the orange tab secures the wire into place. The grounding post is located off the power board on the chassis itself.

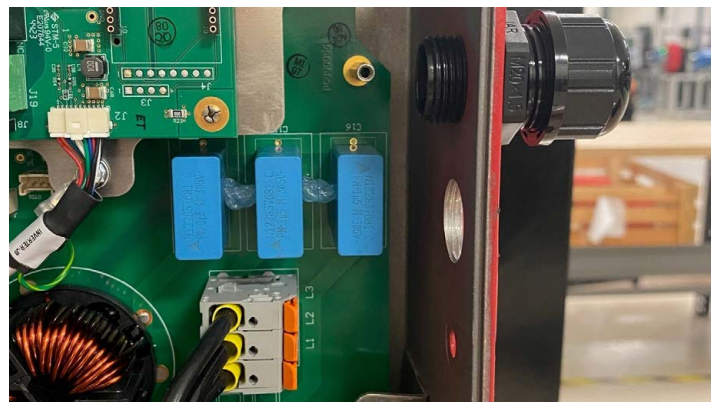

q. LED operation

All Infinitum motors have 3 LEDs viewable on the outside of the VFD that indicate operational status:

Green: Normal operation, 460V input is active

Yellow: Blinking “heartbeat”, Inverter is operational

Red: Fault or important user notification

r. Check motor rotation

Note: If the motor has been tested and the technician has verified motor rotation prior to installation, the facility can elect not to perform this test because of redundancy.

Prerequisites: The motor has been installed, aligned and electrically connected. The fan belt is removed, or coupling is disconnected. The motor must be briefly energized to check for proper rotation.

Steps are outlined below:

1. Review all installation instructions and all warnings prior to testing the motor.
2. Connect AC power
3. Follow all safety precautions and energize the motor briefly to determine rotation. If the motor rotates opposite of intended direction, switch the direction command utilizing I-con software tool.
4. Disconnect AC power.

s. Connect motor to driven equipment

 *Warning: Always disconnect power and practice all safety procedures when installing, troubleshooting, or repairing a motor. Always verify power is secured with a multimeter prior to work. Failure to adhere follow industry standard safety practices can result in serious personal injury or death and equipment damage.*

Prerequisite: Motor rotation has been verified. The final series of steps will place the load on the motor and test system operation.

Steps outlined below:

1. Disconnect power from the motor
2. Attach driven equipment confirming alignment
3. Install all safety covers and connect power
4. Start the system and verify the motor operates properly.

t. Default and user programmable settings

Infinitum EC Aircore motors are shipped with factory default settings for maximum speed, control methods and other values.

To change your motor’s settings, download the [I-con software](#).

5. Motor maintenance

a. Maintenance tasks

If the motor is operating in an environment susceptible to dust, dirt, or exposed to outdoor air, then inspect every 500-hours of operation or every 90 days, whichever occurs first.

If the motor is operating indoors in a clean environment not susceptible to the above-mentioned conditions, then inspect every 6 months.

Maintaining this motor requires completion of both inspection and tasks. Review above warnings. The basic tasks are outlined below:

1. Disconnect motor line power and all associated operating equipment and allow one minute for motor capacitors to discharge.
2. Examine driven equipment for looseness or damage.
3. Inspect the motor output shaft for damages. Replace damaged components and tighten any loose set screws.
4. Make sure the cooling fins and area around the motor are free from dust and debris.
5. Make sure the mounting bolts and hardware are tight and secure.
6. If used, check rubber vibration isolators for cracks and damage.
7. Make sure all wire connections are tight.
8. Inspect internal wires for signs of heat damage.

Any damages noted must be repaired before placing the motor into service.

b. Mechanical

Problems with alignment can cause bearing wear. Lack of maintenance, improper installation, and loose mounting bolts can cause premature bearing wear and motor overloads.

6. Motor Operations

a. Windmilling

Infinitum Aircore EC motors can overcome “windmilling” (reverse rotation due to back pressure in HVAC applications) up to 200 RPM. In windmilling conditions under 200 RPM, the motor will stop the reverse rotation and resume operations in the required operational direction. If the windmilling speed exceeds 200 RPM, alternative solutions are required such as anti-windmilling devices like brakes, clutches, or louvers.

7. Motor drive parameters and data types

The Aircore EC motor parameters can be found [here](#).

8. Related Documents

[I-con: Infinitum motor control software manual](#)

[QSG: Quick start guide for wiring overview](#)

[MST: Rightsize motor to application with motor selection tool](#)

[BACnet user manual: Infinitum's BACnet implementation details](#)

[Software and firmware download: resources](#)

Appendix & troubleshooting guide

These instructions do not cover all variations in equipment nor provide information for every possible condition in installation, operation, or maintenance. For additional information, contact Infinium Support.

Motor troubleshooting and service must be performed by qualified personnel with proper tools and equipment. LOTO operation should be followed per company guidelines.

‘Motor’ refers to the motor system consisting of motor and UFD.

| Issue | Observations | Probable Cause | Mitigation |
|--|--|---|---|
| Motor unresponsive/ fails to start | No LED status lights | No 460-480 voltage | <ul style="list-style-type: none"> Check incoming voltage. If no incoming voltage contact site electrician. Retry motor once voltage has been confirmed. If voltage is confirmed go to next troubleshooting step. |
| | Nearby motors also inoperable | No 460-480 voltage | <ul style="list-style-type: none"> Check incoming voltage. If no incoming voltage contact site electrician. Retry motor once voltage has been confirmed. If voltage is confirmed go to next troubleshooting step. |
| Motor fails to start with confirmed VAC | No LED status lights on motor | Internal failure | <ul style="list-style-type: none"> Perform LOTO. Remove VFD access cover on Gen2 or entire drive cover on Gen3 VFD. Confirm connections for all internal wiring connections, particularly the main 460 VAC line-in wiring and the cable from the Inverter board to CIO board. Using a multimeter, determine continuity of the three fuses. If any are open, record which one, RMA motor. Close cover and try power again if no open fuses. If no LEDs are lighted, RMA motor |
| | Solid green LED, normal yellow heartbeat LED, no red LED: serial Modbus connection incomplete, grounded, or reverse polarity | Lack of external communication to the motor | <ul style="list-style-type: none"> Correct the polarity. Correct the ground/shield/drain by termination at the main RTU device with a contiguous, isolated run from end of line to end of line. Remove any wrongful ground locations. Verify each connection point or break for proper termination of the conductors along the daisy chain. Verify the correct wire for the application is being used. |
| | Solid green LED, normal yellow heartbeat LED, no red LED: analog control unresponsive or incorrect motor speed | Incorrect signal voltage or incorrect I/O terminal connection | <ul style="list-style-type: none"> The +24v terminal on the I/O board is OUTPUT in DC voltage only. The digital input 1(DIN1) needs to receive 24v DC for the motor to start at minimum speed which can be set under Parameter Settings>Terminal Settings>AI1 Min Setting (%). The analog input(A_IN) by default will accept 0-10v for 0-100% speed. |
| | Red LED Fault LED illuminated | Internal electrical issue | <ul style="list-style-type: none"> Use MCS to determine fault, and Serial # for motor. Photograph motor label and reach out to Infinium Support for assistance. |
| No connection to Motor Control Software via TCP (Ethernet) | LEDs (green on, yellow flashing), No red LED | Incorrect motor operating mode | <ul style="list-style-type: none"> Change MCS operating mode on upper left corner of home screen. |
| | LEDs (green on, yellow flashing). No red LED | Incorrect IP address | <ul style="list-style-type: none"> Confirm static IP address: 172 17 20 153 / 255 255 0 0 |

| Issue | Observations | Probable Cause | Mitigation |
|--|---|------------------------------|--|
| I-con connects to motor, but motor won't start | Fault observed in upper right corner of MCS | Internal motor fault | <ul style="list-style-type: none"> • Create a save state to record the data. • Confirm the motor parameters are set to what is needed for the spec of the fans. • Record the state of the motor and the order of the faults as they are listed. • Refer to Fault Page on the Infinitem Support page for information. • Clear Faults with the MCS and see if the motor will restart at the Minimum RPM. • If the motor starts, then observe its operation for 15 mins listening and looking for any defects. • If the observation is ok turn the motor to mid the full RPM for 10 mins each. • If the motor runs for both with no issues, then remove the laptop and return motor to service. |
| I-con connects to motor, but motor has Modbus or Serial communication issues | MCS connects to motor. No operation via Modbus or Serial | Cable, or Board issue | <ul style="list-style-type: none"> • LOTO the motor at the mainline disconnect and follow your company procedure to ensure no power. • Check L1, L2, L3 on the motor after LOTO to confirm no power. • Are wires stripped properly and inserted into the terminal – Remove wires and re-seat to confirm. • Review boards and wiring inside of motor access panel to determine if anything looks burnt, unplugged, or out of place. • Contact Infinitem Support with any concerns. Pictures will help. • MAKE SURE MOTOR HAS POWER REMOVED AND LOTO – Then physically spin motor to see if it spins freely. • If there is resistance record it with a video and send to Infinitem Support. • If motor spins freely then remove the CIO 24V DC Comm wires and use a meter to check them. • Check all wires in the array of fans that are for the Modbus/ Coms. • Confirm shields are terminated where needed, solid connections are made, and wires are not pinched/nicked anywhere. • It may be necessary to remove all connections and reset them back in the terminals/connectors. • It is very important to have good connections on the Modbus/ Comm side. • Make sure all motors in the array have the end of line jumper or end of line resistor installed per specs and only at the end of line. • Confirm all motors that are not end of line motors have the comm dip-switch in the off position. • Remove field wires for the Modbus comms making sure the ends do not touch and are safely covered with tape or connectors. See Modbus RTU Troubleshooting PN Link • Install wires from USB to RS485 adapter in the comm ports. • See if the motor will run using only the MCS and attached wires. • If YES then there is a field wire issue. • If NO then contact Infinitem Support for a new CIO board. |
| I-con connects to motor but not delivering 100% power | Motor is running, LEDs are normal (green ON, yellow flashing) | Power wiring, or Board issue | <ul style="list-style-type: none"> • Perform LOTO. • Remove VFD access cover on Gen2 or entire drive cover on Gen3 VFD. • Confirm connections for power connections, measure the main 460 VAC line-in wiring for all three phases. • The motor will run even if one phase is lost. |

